Introduction to Refrigeration Systems

Course No: M08-008

Credit: 8 PDH

Elie Tawil, P.E., LEED AP



Continuing Education and Development, Inc.
22 Stonewall Court
Woodcliff Lake, NJ 07677

P: (877) 322-5800
info@cedengineering.com

Chapter 12

Refrigeration

Topics

- 1.0.0 Heat and Refrigeration Principles
- 2.0.0 Mechanical Refrigeration Systems
- 3.0.0 Refrigerants
- 4.0.0 Refrigerant Safety
- 5.0.0 Refrigerant Equipment
- 6.0.0 Installation of Refrigeration Equipment
- 7.0.0 Maintenance, Service, and Repair of Refrigeration Equipment
- 8.0.0 Maintenance of Compressors
- 9.0.0 Maintenance of Motors
- 10.0.0 Logs

Overview

During a deployment, the preservation of food and other necessities that require refrigeration is of the utmost importance. The spoiling of large amounts of galley food or hospital blood reserves due to a malfunctioning refrigerator or freezer can cause serious morale and health problems. Therefore, one of your primary responsibilities as an Utilitiesman is to maintain a unit's refrigeration equipment to ensure proper operation.

This chapter will provide you with the necessary information to understand the principles and theory of refrigeration, the components of mechanical refrigeration systems, and the types of refrigerants and associated equipment. Also covered in this chapter are the methods used for installing, maintaining, and repairing refrigeration equipment, including domestic refrigerators and freezers.

Objectives

When you have completed this chapter, you will be able to do the following:

1. Identify the principles of heating and refrigeration.
2. Describe the components of mechanical refrigeration systems.
3. Identify the different types of refrigerants.
4. State the safety precautions associated with refrigerants.
5. Describe the different types of refrigerant equipment.

6. Describe the installation procedures for refrigerant equipment.
7. Describe the maintenance, service, and repair procedures associated with refrigerant equipment.
8. Describe the maintenance procedures associated with compressors.
9. Describe the maintenance procedures associated with motors.
10. Describe the purpose and use of logs.

Prerequisites

None

This course map shows all of the chapters in Utilitiesman Basic. The suggested training order begins at the bottom and proceeds up. Skill levels increase as you advance on the course map.

Utilities Equipment and Maintenance	▲	U T B A S I C
Air Conditioning		
Refrigeration		
Heating Systems		
Steam Distribution Systems		
Boilers		
Sewage Disposal, Field Sanitation, and Water Treatment		
Prime Movers, Pumps, and Compressors		
Plumbing Fixtures		
Piping System Layout and Plumbing Accessories		
Structural Openings and Pipe Material		
Fundamentals of Water Distribution		
Basic Math, Electrical, and Plumbing Operations		
Plans, Specifications, and Color Coding		

Features of this Manual

This manual has several features which make it easier to use online.

- Figure and table numbers in the text are italicized. The figure or table is either next to or below the text that refers to it.
- The first time a glossary term appears in the text, it is bold and italicized. When your cursor crosses over that word or phrase, a popup box displays with the appropriate definition.
- Audio and video clips are included in the text, with an italicized instruction telling you where to click to activate it.
- Review questions that apply to a section are listed under the Test Your Knowledge banner at the end of the section. Select the answer you choose. If the answer is correct, you will be taken to the next section heading. If the answer is incorrect, you will be taken to the area in the chapter where the information is for review. When you have completed your review, select anywhere in that area to return to the review question. Try to answer the question again.
- Review questions are included at the end of this chapter. Select the answer you choose. If the answer is correct, you will be taken to the next question. If the answer is incorrect, you will be taken to the area in the chapter where the information is for review. When you have completed your review, select anywhere in that area to return to the review question. Try to answer the question again.

1.0.0 HEAT and REFRIGERATION PRINCIPLES

Refrigeration is the process of removing heat from an area or a substance. It is usually done by an artificial means of lowering the temperature, such as by the use of ice or mechanical refrigeration, which is a mechanical system or apparatus, designed and constructed to transfer heat from one substance to another.

Since refrigeration deals entirely with the removal or transfer of heat, it is important that you have a clear understanding of the nature and effects of heat.

1.1.0 Nature of Heat

Heat is a form of energy contained to some extent in every substance on earth. All known elements are made up of very small particles known as atoms, which form molecules when joined together. These molecules are particular to the form they represent. For example, carbon and hydrogen in certain combinations form sugar and in others form alcohol.

Molecules are in a constant state of motion. Heat is a form of molecular energy that results from the motion of these molecules. The temperature of the molecules dictates to a degree the molecular activity within a substance. For this reason, substances exist in three different states or forms—solid, liquid, and gas.

Water, for example, may exist in any one of these states. As ice, it is a solid; as water, it is a liquid; as steam, it is a gas (vapor).

When you add heat to a substance, the rate of molecular motion increases causing the substance to change from a solid to a liquid, and then to a gas (vapor). For example, in a cube of ice, molecular motion is slow, but as heat is added, molecular activity increases, changing the solid "ice" to a liquid "water" (Figure 12-1).

Further application of heat forces the molecules to greater separation and speeds up their motion so that the water changes to steam. The steam formed no longer has a definite volume, such as a solid or liquid has, but expands and fills whatever space is provided for it.

Heat cannot be destroyed or lost. However, it can be transferred from one body or substance to another or to another form of energy. Since heat is not in itself a substance, it can best be considered in

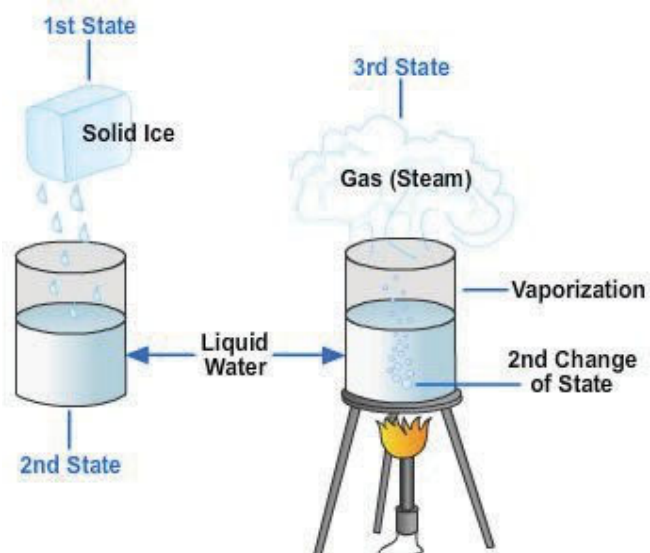

Figure 12-1 – The three states of matter.

relation to its effect on substances or bodies. When a body or substance is stated to be cold, the heat that it contains is less concentrated or less intense than the heat in some warmer body or substance used for comparison.

1.2.0 Unit of Heat

In the theory of heat, the speed of the molecules indicates the temperature or intensity of heat, while the number of molecules of a substance indicates the quantity of heat.

The intensity and quantity of heat may be explained in the following simple way. The water in a quart jar and in a 10-gallon container may have the same intensity or temperature, but the quantity of heat required to raise these amounts of water to a higher uniform temperature (from their present uniform temperature) will differ greatly. The 10 gallons of water will absorb a greater amount of heat than the quart jar of water.

The amount of heat added to, or subtracted from, a body can best be measured by the rise or fall in temperature of a known weight of a substance. The standard unit of heat measure is the amount of heat necessary to raise the temperature of 1 pound of water 1°F at sea level when the water temperature is between 32°F and 212°F. Conversely, it is also the amount of heat that must be extracted to lower by 1°F the temperature of a pound of water between the same temperature limits. This unit of heat is called a **British thermal unit (Btu)**. The Btu's equivalent in the metric system is the calorie, which is the amount of heat required to raise one gram of water 1° Celsius.

Suppose that the temperature of 2 pounds of water was raised from 35°F to 165°F. To find the number of Btu required to increase the temperature, subtract 35 from 165. This equals a 130° temperature rise for 1 pound of water.

For example:

$$\begin{array}{r} 165 \\ - 35 \\ \hline 130 \end{array} \qquad 130 \times 2 = 260$$

Since 2 pounds of water were heated, multiply 130 by 2, which equals 260 Btu required to raise 2 pounds of water from 35°F to 165°F.

1.3.0 Measurement of Heat

The usual means of measuring temperature is a thermometer. It measures the degree or intensity of heat and usually consists of a glass tube with a bulb at the lower portion of the tube that contains mercury, colored alcohol, or a volatile liquid. The nature of these liquids causes them to rise or fall uniformly in the hollow tube with each degree in temperature change. Thermometers are used to calibrate the controls of refrigeration. The two most common thermometer scales are the Fahrenheit and the Celsius.

On the Fahrenheit scale, there is a difference of 180° between freezing (32°) and the boiling point (212°) of water. On the Celsius scale, you have only 100° difference between the same points (0° freezing and 100° boiling point).

Of course, a Celsius reading can be converted to a Fahrenheit reading, or vice versa. This can be done using the following formula:

$$F = (C \times 1.8) + 32$$

To change Fahrenheit to a Celsius reading, use the following formula:

$$C = (F - 32) \div 1.8$$

1.4.0 Transfer of Heat

Heat flows from a substance of higher temperature to bodies of lower temperature in the same manner that water flows down a hill, and like water, it can be raised again to a higher level so that it may repeat its cycle.

When two substances of different temperatures are brought in contact with each other, the heat will immediately flow from the warmer substance to the colder substance. The greater the difference in temperature between the two substances, the faster the heat flow. As the temperature of the substances tends to equalize, the flow of heat slows and stops completely when the temperatures are equalized. This characteristic is used in refrigeration. The heat of the air, of the lining of the refrigerator, and of the food to be preserved is transferred to a colder substance, called the refrigerant.

Three methods by which heat may be transferred from a warmer substance to a colder substance are conduction, convection, and radiation. These principles are explained in Utilitiesman Basic Chapter 11.

1.5.0 Specific Heat

Specific heat is the ratio between the quantity of heat required to change the temperature of 1 pound of any substance 1°F, as compared to the quantity of heat required to change 1 pound of water 1°F. Specific heat is equal to the number of Btu required to raise the temperature of 1 pound of a substance 1°F. For example, the specific heat of milk is .92, which means that 92 Btu will be needed to raise 100 pounds of milk 1°F. The specific heat of water is 1, by adoption as a standard, and specific heat of another substance (solid, liquid, or gas) is determined experimentally by comparing it to water. Specific heat also expresses the heat-holding capacity of a substance compared to that of water.

A key rule to remember is that .5 Btu of heat is required to raise 1 pound of ice 1°F when the temperature is below 32°F; and .5 Btu of heat is required to raise 1 pound of steam 1°F above the temperature of 212°F.

1.6.0 Sensible Heat

Heat that is added to, or subtracted from, a substance that changes its temperature but not its physical state is called sensible heat. It is the heat that can be indicated on a thermometer. This is the heat human senses also can react to, at least within certain ranges. For example, if you put your finger into a cup of water, your senses readily tell you whether it is cold, cool, tepid, hot, or very hot. Sensible heat is applied to a solid, a liquid, or a gas/vapor as indicated on a thermometer. The term sensible heat does not apply to the process of conversion from one physical state to another.

1.7.0 Latent Heat

Latent heat, or hidden heat, is the term used for the heat absorbed or given off by a substance while it is changing its physical state. When this occurs, the heat given off or absorbed does NOT cause a temperature change in the substance. In other words, sensible heat is the term for heat that affects the temperature of things; latent heat is the term for heat that affects the physical state of things.

To understand the concept of latent heat, you must realize that many substances may exist as solids, as liquids, or as gases, depending primarily upon the temperatures and pressure to which they are subjected. To change a solid to a liquid or a liquid to a gas, you would add heat; to change a gas to a liquid or a liquid to a solid, you would remove

heat. Suppose you take an uncovered pan of cold water and put it over a burner. The sensible heat of the water increases and so does the temperature. As you continue adding heat to the water in the pan, the temperature of the water continues to rise until it reaches 212°F. What is happening? The water is now absorbing its latent heat and is changing from a liquid to a vapor. The heat required to change a liquid to a gas without any change in temperature is known as the Latent heat of vaporization.

Suppose you take another pan of cold water, and put it in a place where the temperature is below 32°F. The water gradually loses heat to its surroundings, and the temperature of the water drops to 32°F until all the water has changed to ice. While the water is changing to ice, however, it is still losing heat to its surroundings. The heat that must be removed from a substance to change it from a liquid to a solid without change in temperature, is called the Latent heat of fusion. Note the amount of heat required to cause a change of state (or the amount of heat given off when a substance changes its state) varies according to the pressure under which the process takes place.

Figure 12-2 shows the relationship between sensible heat and latent heat for one substance - water at atmospheric pressure. To raise the temperature of 1 pound of ice from 0°F to 32°F, you must add 16 Btu. To change the pound of ice at 32°F to a pound of water at 32°F, you add 144 Btu (latent heat of fusion). There is no change in temperature while the ice is melting. After the ice is melted, however, the temperature of the water is raised when more heat is applied. When 180 Btu are added, the water boils. To change a pound of water at 212°F to a pound of steam at 212°F, you must add 970 Btu (latent heat of vaporization). After the water is converted to steam at 212°F, adding more heat causes a rise in the temperature of the steam. When you add 44 Btu to the steam at 212°F, the steam is superheated to 300°F.

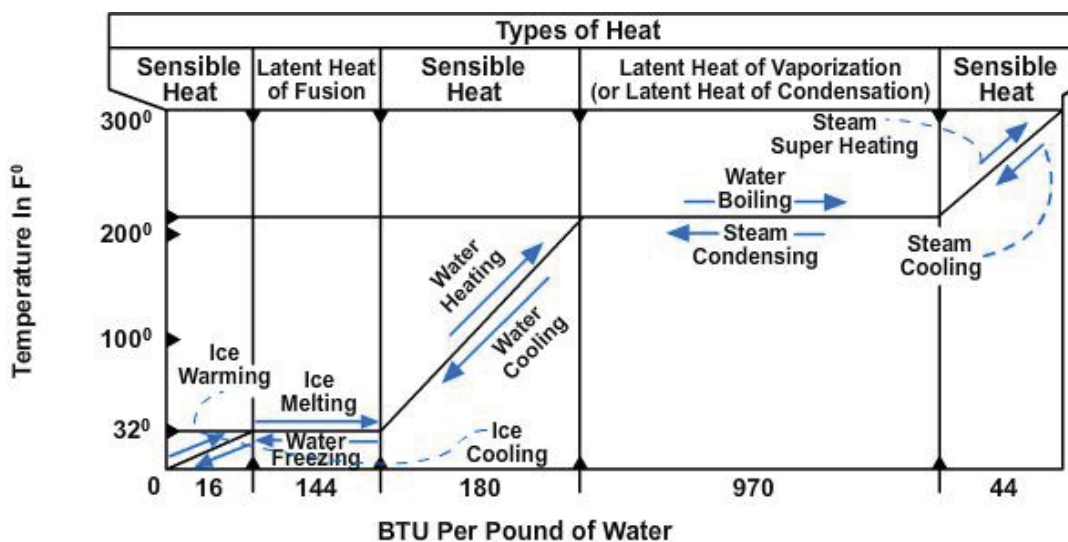

Figure 12-2 - Relationship between temperature and the amount of heat required per pound (for water at atmospheric pressure).

1.8.0 Total Heat

The sum of sensible heat and latent heat is called "total heat." Since measurements of the total heat in a certain weight of a substance cannot be started at absolute zero, a temperature is adopted at which it is assumed that there is no heat; and tables of data are constructed on that basis for practical use. Data tables giving the heat content of the most commonly used refrigerants start at 40°F below zero as the assumed point of no heat; tables for water and steam start at 32°F above zero. Tables of data usually contain a notation showing the starting point for heat content measurement.

1.9.0 Day-Ton of Refrigeration

A day-ton of refrigeration (sometimes incorrectly called a ton of refrigeration) is the amount of refrigeration produced by melting 1 ton of ice at a temperature of 32°F in 24 hours. A day-ton is often used to express the amount of cooling produced by a refrigerator or air conditioner. For example, a 1-ton air conditioner can remove as much heat in 24 hours as 1 ton of 32°F ice that melts and becomes water at 32°F.

It is a rate of removing heat, rather than a quantity of heat. A rate can be converted to Btu per day, hour, or minute. To find the rate, proceed as follows:

- Per day: Multiply 2,000 (number of pounds of ice in 1 ton) by 144 (latent heat of fusion per pound) = 288,000 Btu per day
- Per hour: 288,000 (Btu per day) ÷ 24 (hours in a day) = 12,000 So,

a "1-ton" air-conditioner would have a rating of 12,000 Btu per hour.

1.10.0 Pressure

Pressure is defined as a force per unit area. It is usually measured in pounds per square inch (psi). Pressure may be in one direction, several directions, or in all directions (*Figure 12-3*). Pascal's law is utilized when discussing hydraulic or fluid pressures. Pascal's law states that pressure applied to a confined liquid is transmitted undiminished in all directions and acts with equal force on all equal areas, at right angles to those areas. According to Pascal's law, any force applied to a confined fluid is transmitted in all directions throughout the fluid regardless of the shape of the container.

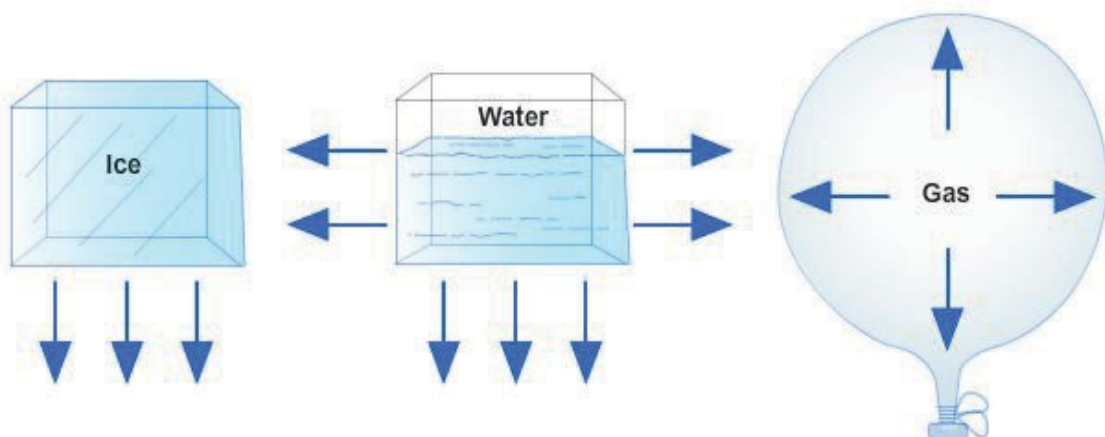

Figure 12-3 – Exertion of pressures.

The ice (solid) exerts pressure downward. The water (fluid) exerts pressure on all wetted surfaces of the container. Gases exert pressure on all inside surfaces of their containers.

Pressure is usually measured on gauges that have one of two different scales. One scale is read as so many pounds per square inch gauge (psig) and indicates the pressure above atmospheric pressure surrounding the gauge. The other type of scale is read as so many pounds per square inch absolute (psia) and indicates the pressure above absolute zero pressure (a perfect vacuum).

1.10.1 Atmospheric Pressure

Atmospheric pressure is the pressure of the weight of air above a point on, above, or under the earth. At sea level, atmospheric pressure is 14.7 psia (*Figure 12-4*). As one ascends, the atmospheric pressure decreases about 1.0 psi for every 2,343 feet. Below sea level in excavations and depressions, atmospheric pressure increases. Pressures underwater differ from those under air only because the weight of the water must be added to the pressure of the air.

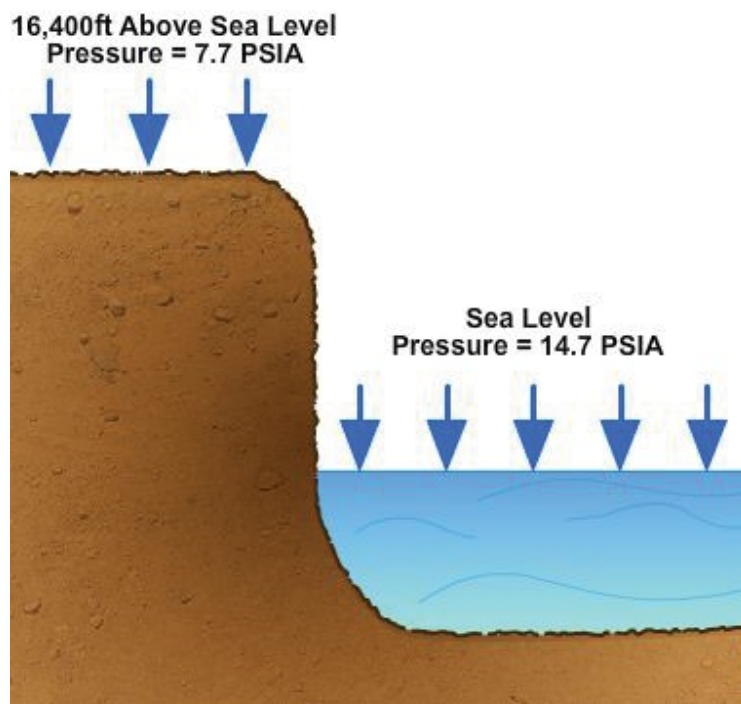

Figure 12-4 – Atmospheric pressure.

1.10.2 Scale Relationships

A relationship exists between the readings of a gauge calibrated in psig and calibrated in psia. As shown in *Table 12-1*, when the psig gauge reads 0, the psia gauge reads the atmospheric pressure (14.7 psia at sea level). In other words, the psia reading equals the psig reading plus the atmospheric pressure (7.7 psia at 16,400 feet) or, a psig reading equals the psia reading minus the atmospheric pressure.

Table 12-1 –Pressure Relationship.

ABSOLUTE SCALE (PSIA)	GAUGE SCALE (PSIG)	INCHES OF MERCURY	INCHES OF WATER
44.7	30	NOT USED	NOT USED
24.7	10	NOT USED	NOT USED
14.7	0	0	0
0	NOT USED	- 30	- 408

For pressure less than the atmospheric pressure (partial vacuums), a measuring device with a scale reading in inches of mercury (Hg) or in inches of water (H₂O) is used. A perfect vacuum is equal to -30 inches of mercury or -408 inches of water (*Table 12-1*). In refrigeration work, pressures above atmospheric are measured in pounds per square inch, and pressures below atmospheric are measured in inches of mercury.

1.10.3 Effects of Pressure on Gases

The exertion of pressure on a substance with a constant temperature decreases its volume in proportion to the increase of pressure. For example, suppose that a given amount of gas is placed in a cylinder that is sealed on one end and has a movable piston on the other end. When 60 psi of absolute pressure is exerted on the piston as the volume of the gas is compressed to 3 cubic feet (*Figure 12-5, View A*). When 90 psi of absolute pressure is exerted on the piston, the volume of the gas is compressed to 1.5 cubic feet (*Figure 12-5, View B*). Finally, when 180 psi of absolute pressure is exerted on the piston, the volume of the gas is compressed to 1 cubic foot (*Figure 12-5, View C*). Thus, if a given amount of gas is confined in a container and subject to changes of pressure, its volume changes, so the product of volume multiplied by absolute pressure is always the same.

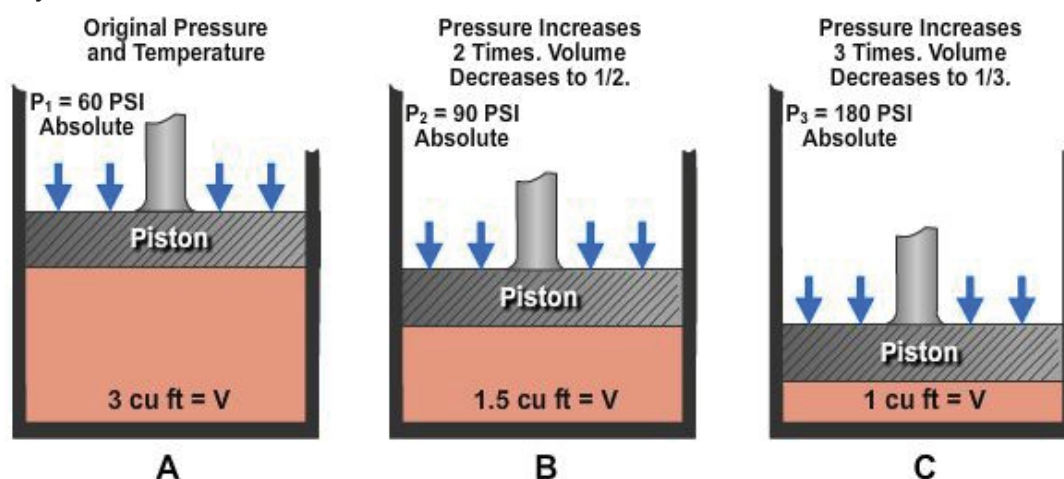

Figure 12-5 – Pressure-volume relationship.

Pressure has a relationship to the boiling point of a substance. There is a definite temperature at which a liquid boils for every definite pressure exerted upon it.

For instance, water boils at 212°F at atmospheric pressure (14.7 psia) (*Figure 12-6, View A*). The same water boils at 228°F if the pressure is raised 5.3 psig (20 psia),

(Figure 12-6, View B). On the other hand, the same water boils at 32°F in a partial vacuum of 29.74 inches of mercury (Hg) (Figure 12-7).

This effect of reduced pressure on the boiling temperature of refrigerants makes the operation of a refrigeration system possible. The pressure-temperature relationship chart in Table 12-2 gives the pressures for several different refrigerants.

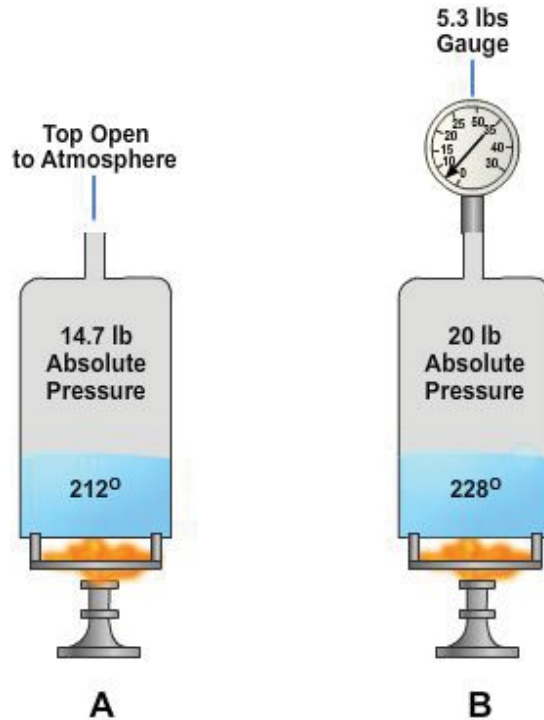

Figure 12-6 – A. Water boils at atmospheric pressure; B. Water boils at 20 psia absolute pressure.

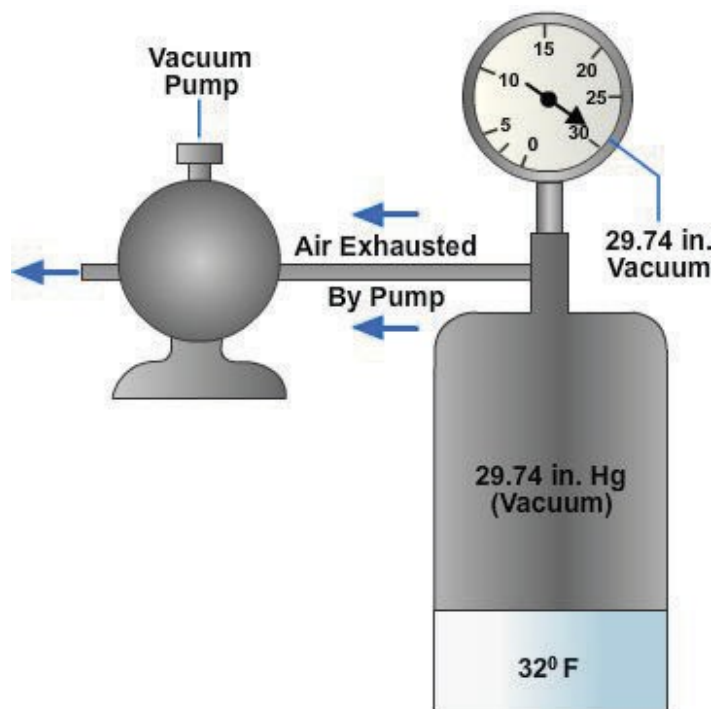

Figure 12-7 – Water boils in a vacuum.

Table 12-2 – Pressure-Temperature Relationship Chart.

Temp °F	113	141b	123	11	114	124	134	12	500	22	502	125
-40.0	29.5	29.0	28.8	28.4	26.1	22.8*	14.7	11.0	7.6	0.6	4.1	4.9
-35.0	29.4	28.8	28.6	28.1	25.4		12.3	8.4	4.6	2.6	6.5	
-30.0	29.3	28.6	28.3	27.8	24.7	20.2*	9.7	5.5	1.2	4.9	9.2	10.6
-25.0	29.2	28.3	28.1	27.4	23.8		6.8	2.3	1.2	7.5	12.1	
-20.0	29.0	28.1	27.7	27.0	22.9	16.9*	3.6	0.6	3.2	10.2	15.3	17.4
-15.0	28.8	27.7	27.3	26.6	21.8		0.0	2.5	5.4	13.2	18.8	
-10.0	28.7	27.3	26.9	26.0	20.6	12.7*	2.0	4.5	7.8	16.5	22.6	25.6
-5.0	28.4	26.9	26.4	25.4	19.3		4.1	6.7	10.4	20.1	26.7	
0.0	28.2	26.4	25.8	24.7	17.8	7.6*	6.5	9.2	13.3	24.0	31.1	35.1
5.0	27.9	25.8	25.2	23.0	16.2		9.1	11.8	16.4	28.3	35.9	
10.0	27.5	25.2	24.5	23.1	14.4	1.4*	12.0	14.7	19.7	32.8	41.0	46.3
15.0	27.2	24.5	23.7	22.1	12.4		15.1	17.7	23.3	37.8	46.5	
20.0	26.7	23.7	22.8	21.1	10.2	3.0	18.4	21.1	27.2	43.1	52.5	59.2
25.0	26.3	22.8	21.8	19.9	7.8		22.1	24.6	31.4	48.8	58.8	
30.0	25.7	21.8	20.7	18.6	5.1	7.5	26.1	28.5	36.0	54.9	65.6	74.1
35.0	25.1	20.7	19.5	17.1	2.2		30.4	32.6	40.8	61.5	72.8	
40.0	24.4	19.5	18.1	15.6	0.4	12.7	35.0	37.0	46.0	68.5	80.5	91.2
45.0	23.7	18.1	16.6	13.8	2.1		40.0	41.7	51.6	76.1	88.7	
50.0	22.9	16.7	15.0	12.0	3.9	18.8	45.4	46.7	57.5	84.1	97.4	110.6
55.0	21.9	13.1	13.1	9.9	5.9		51.2	52.1	63.8	92.6	106.6	
60.0	20.9	13.4	11.2	7.7	8.0	25.9	57.4	57.8	70.6	101.6	116.4	132.8
65.0	19.8	11.5	9.0	5.2	10.3		64.0	63.8	77.7	111.3	127.6	
70.0	18.6	9.4	6.6	2.6	12.7	34.1	71.1	70.2	85.3	121.4	137.6	157.8
75.0	17.3	7.2	4.1	0.1	15.3		78.6	77.0	93.4	132.2	149.1	
80.0	15.8	4.8	1.3	1.6	18.2	43.5	86.7	84.2	101.9	143.7	161.2	186.0
85.0	14.2	2.3	0.9	3.3	21.2		95.2	91.7	110.9	155.7	174.0	
90.0	12.5	0.2	2.5	5.0	24.4	54.1	104.3	99.7	120.5	168.4	187.4	217.5
95.0	10.6	1.7	4.2	6.9	27.8		113.9	108.2	130.5	181.8	201.4	
100.0	8.6	3.2	6.1	8.9	31.4	66.2	124.1	117.0	141.1	196.0	216.2	252.7
105.0	6.4	4.8	8.1	11.1	35.3		134.9	126.4	152.2	210.8	231.7	
110.0	4.0	6.6	10.2	13.4	39.4	79.7	146.3	136.2	163.9	226.4	247.9	291.6
115.0	1.4	8.4	12.6	15.9	43.8		158.4	146.5	176.3	242.8	264.9	
120.0	0.7	10.4	15.0	18.5	48.4	94.9	171.1	157.3	189.2	260.0	282.7	334.3

Note: Vapor pressures in psig, except (*) which are inches of mercury (Hg).

An increase in the temperature of a refrigerant, results in an increase in pressure, and a decrease in temperature causes a decrease in pressure. By the same token, a decrease in pressure results in a corresponding decrease in temperature.

This means that as the pressure of a refrigerant is increased, so is the temperature at which the refrigerant boils. Thus, by regulating the pressure of the refrigerant, the temperature at which evaporation takes place and at which the latent heat of evaporation is used can be controlled.

1.11.0 Vaporization

Vaporization is the process of changing a liquid to vapor, either by evaporation or boiling. When a glass is filled with water and exposed to the rays of the sun for a day or two, you should note that the water level drops gradually (*Figure 12-8*). The loss of water is due to evaporation.

In this case, evaporation takes place only at the surface of the liquid, and is gradual, but the evaporation of the water can be speeded up if additional heat is applied to it. In this case, the boiling of the water takes place throughout the interior of the liquid. Thus the absorption of heat by a liquid causes it to boil and evaporate.

Vaporization can also be increased by reducing the pressure on the liquid (*Figure 12-9*). Pressure reduction lowers the temperature at which liquid boils and hastens its evaporation. When a liquid evaporates, it absorbs heat from warmer surrounding objects and cools them. Refrigeration by evaporation is based on this method. The liquid is allowed to expand under reduced pressure, vaporizing and extracting heat from the container (freezing compartment), as it changes from a liquid to a gas. After the gas is expanded (and heated), it is compressed, cooled, and condensed into a liquid again.

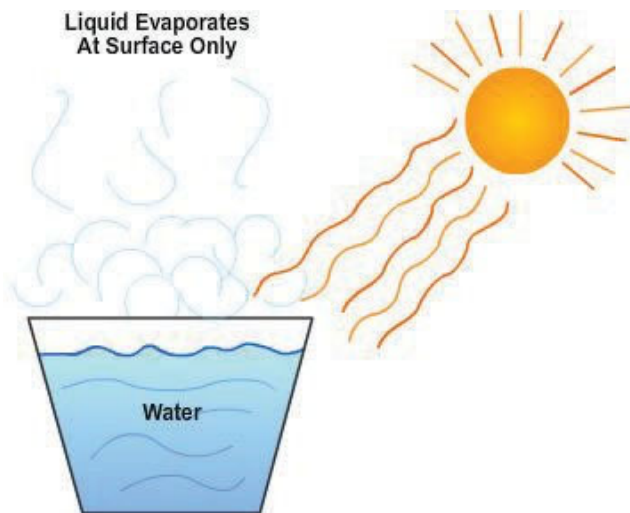

Figure 12-8 – Normal surface evaporation.

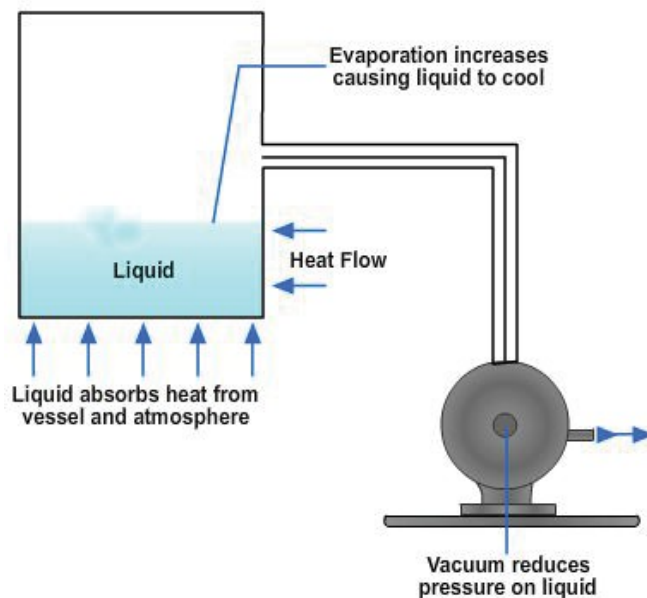

Figure 12-9 – Evaporation by pressure reduction.

1.12.0 Condensation

Condensation is the process of changing a vapor into a liquid. For example, in *Figure 12-10*, a warm atmosphere gives up heat to a cold glass of water, causing moisture to condense out of the air and form on the outside surface of the glass. Thus the removal of heat from a vapor causes the vapor to condense.

An increase in pressure on a confined vapor also causes the vapor to change to a liquid. This fact is shown in *Figure 12-11*.

When the compressor increases the pressure on the vapor, the condensing vapor changes to a liquid and gives up heat to the cooler surrounding objects and atmosphere.

These conditions exist when the vaporized refrigerant is compressed by the compressor



Figure 12-10 - Condensation of moisture on a glass of cold water.

of a refrigeration system and forced into the condenser. The condenser removes the superheat, latent heat of vaporization, and in some cases, sensible heat from the refrigerant.

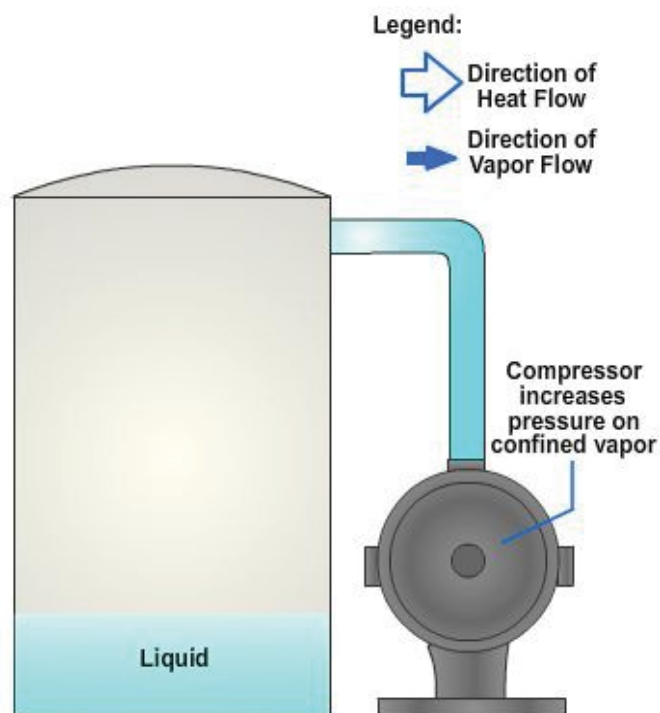

Figure 12-11 – Pressure causes a vapor to condense.

Test Your Knowledge (Select the Correct Response)

1. What term is used for the heat absorbed or given off by a substance while it is changing its physical state?
 - A. Sensible
 - B. Specific
 - C. Latent
 - D. Total

2.0.0 MECHANICAL REFRIGERATION SYSTEMS

Mechanical refrigeration systems are an arrangement of components in a system that puts the theory of gases into practice to provide artificial cooling. To do this, you must provide the following: (1) a metered supply of relatively cool liquid under pressure; (2) a device in the space to be cooled that operates at reduced pressure so that when the cool, pressurized liquid enters, it will expand, evaporate, and take heat from the space to be cooled; (3) a means of repressurizing (compressing) the vapor; and (4) a means of condensing it back into a liquid, removing its superheat, latent heat of vaporization, and some of its sensible heat.

Every mechanical refrigeration system operates at two different pressure levels. The dividing line is shown in *Figure 12-12*. The line passes through the discharge valves of the compressor on one end and through the orifice of the metering device or expansion valve on the other.

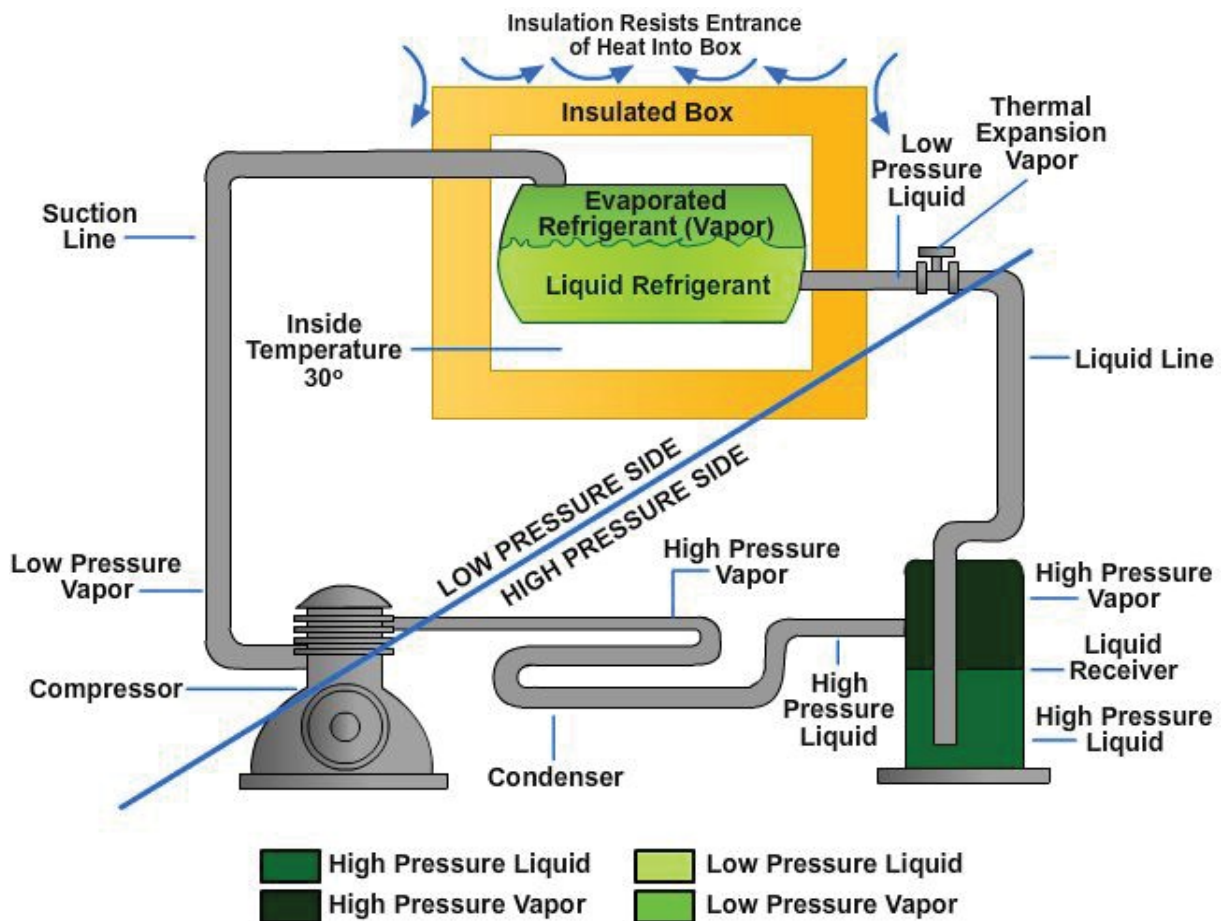

Figure 12-12 – Refrigeration cycle.

The high-pressure side of the refrigeration system consists of all the components that operate at or above condensing pressure. These components are the discharge side of the compressor, the condenser, the receiver, and all interconnected tubing up to the metering device or expansion valve.

The low-pressure side of a refrigeration system consists of all the components that operate at or below evaporating pressure. These components comprise the low-pressure side of the expansion valve, the evaporator, and all the interconnecting tubing up to and including the low side of the compressor.

Refrigeration mechanics call the pressure on the high side discharge pressure, head pressure, or high-side pressure. On the low side, the pressure is called suction pressure or low-side pressure.

The refrigeration cycle of a mechanical refrigeration system may be explained by using *Figure 12-12*. The pumping action of the compressor (1) draws vapor from the evaporator (2). This action reduces the pressure in the evaporator, causing the liquid particles to evaporate. As the liquid particles evaporate, the evaporator is cooled. Both the liquid and vapor refrigerant tend to extract heat from the warmer objects in the insulated refrigerator cabinet. The ability of the liquid to absorb heat as it vaporizes is very high in comparison to that of the vapor. As the liquid refrigerant is vaporized, the low-pressure vapor is drawn into the suction line by the suction action of the compressor (1). The evaporation of the liquid refrigerant would soon remove the entire refrigerant from the evaporator if it were not replaced. The replacement of the liquid refrigerant is usually controlled by a metering device or expansion valve (3). This device acts as a restrictor to the flow of the liquid refrigerant in the liquid line. Its function is to change the high-pressure, subcooled liquid refrigerant to low-pressure, low-temperature liquid particles, which will continue the cycle by absorbing heat.

The refrigerant low-pressure vapor drawn from the evaporator by the compressor through the suction line in turn is compressed by the compressor to a high-pressure vapor, which is forced into the condenser (4). In the condenser, the high-pressure vapor condenses to a liquid under high pressure and gives up heat to the condenser. The heat is removed from the condenser by the cooling medium of air or water. The condensed liquid refrigerant is then forced into the liquid receiver (5) and through the liquid line to the expansion valve by pressure created by the compressor, making a complete cycle.

Although the receiver is indicated as part of the refrigeration system in *Figure 12-12*, it is not a vital component. However, the omission of the receiver requires exactly the proper amount of refrigerant in the system. The refrigerant charge in systems without receivers is to be considered critical, as any variations in quantity affect the operating efficiency of the unit.

The refrigeration cycle of any refrigeration system must be clearly understood by a mechanic before repairing the system. Knowing how a refrigerant works makes it easier to detect faults in a refrigeration system.

2.1.0 Components

The refrigeration system consists of four basic components:

- Compressor
- Liquid receiver
- Evaporator
- Control devices

These components are essential for any system to operate on the principles previously discussed. Information on these components is described in the following sections.

2.1.1 Compressors

The purpose of the compressor is to withdraw the heat-laden refrigerant vapor from the evaporator and compress the gas to a pressure that will liquefy in the condenser. The designs of compressors vary, depending upon the application and type of refrigerant. There are three types of compressors classified according to the principle of operation-reciprocating, rotary, and centrifugal.

Many refrigerator compressors have components besides those normally found on compressors, such as unloaders, oil pumps, mufflers, and so on. These devices are too complicated to explain here. Before repairing any compressor, check the manufacturer's manual for an explanation of their operation, adjustment, and repair.

2.1.1.1 External-Drive Compressor

An external drive or open-type compressor is bolted together. Its crankshaft extends through the crankcase and is driven by a flywheel (pulley) and belt, or it can be driven directly by an electric motor. A leak-proof seal must be maintained where the crankshaft extends out of the crankcase of an open-type compressor. The seal must be designed to hold the pressure developed inside of the compressor. It must prevent refrigerant and oil from leaking out and prevent air and moisture from entering the compressor. Two types of seals are used-the stationary bellows seal and the rotating bellows seal.

An internal stationary crankshaft seal consists of a corrugated thin brass tube (seal bellows) fastened to a bronze ring (seal guide) at one end and to the flange plate at the other (Figure 12-13). The flange plate is bolted to the crankcase with a gasket between the two units. A spring presses the seal guide mounted on the other end of the bellows against a seal ring positioned against the shoulder of the crankshaft. As the pressure builds up in the crankcase, the bellows tend to lengthen, causing additional force to press the seal guide against the seal ring. Oil from

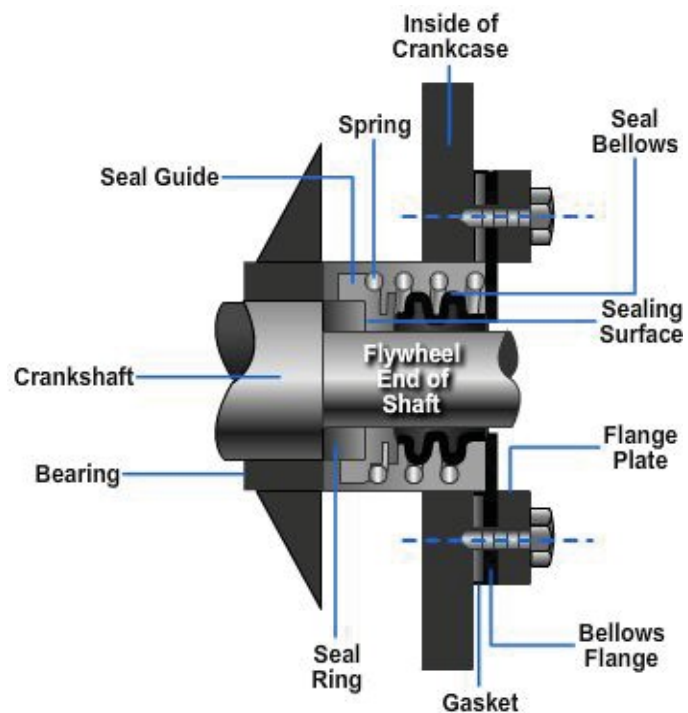

Figure 12-13 - Internal stationary bellows crankshaft seal.

the crankcase lubricates the surfaces of the seal guide and seal ring. This forms a gastight seal whether the compressor is operating or idle.

An external stationary bellows crankshaft seal is shown in *Figure 12-14*. This seal is the same as the internal seal, except it is positioned on the outside of the crankcase.

An external rotating bellows crankcase seal is shown in *Figure 12-15*. This seal turns with the crankshaft. This seal also consists of a corrugated thin brass tube (seal bellows) with a seal ring fastened to one end and a seal flange fastened to the other. A seal spring is enclosed within the bellows. The complete bellows assembly slips on the end of the crankshaft and is held in place by a nut. The seal ring that is the inner portion of the bellows is positioned against a non-rotating seal fastened directly to the crankcase.

During operation, the complete bellows assembly rotates with the shaft, causing the seal ring to rotate against the stationary seal. The pressure of the seal spring holds the seal ring against the seal. The expansion of the bellows caused by the pressure from the crankcase also exerts pressure on the seal ring. Because of this design, double pressure is exerted against the seal ring to provide a gastight seal.

2.1.1.2 Hermetic Compressor

In the hermetically sealed compressor, the electric motor and compressor are both in the same airtight (hermetic) housing and share the same shaft. *Figure 12-16* shows a hermetically sealed unit. Note that after assembly, the two halves of the case are welded together to form an airtight cover.

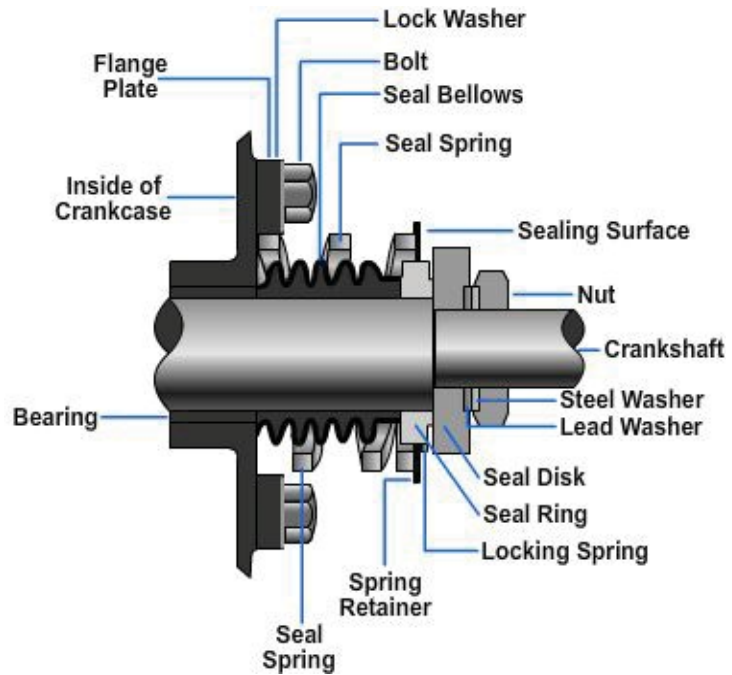

Figure 12-14 - External stationary bellows crankshaft seal.

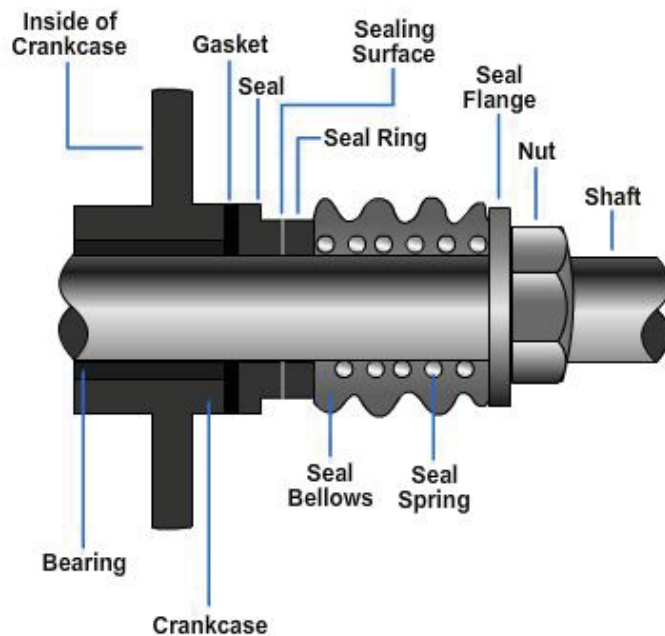

Figure 12-15 - External rotating bellows crankshaft seal.

Figure 12-17 shows an accessible type of hermetically sealed unit. The compressor in this case is a double-piston reciprocating type. Other compressors may be of the centrifugal or rotary types.

Cooling and lubrication are provided by the circulating oil and the movement of the refrigerant vapor throughout the case. The advantages of the hermetically sealed unit (elimination of pulleys, belts and other coupling methods, elimination of a source of refrigerant leaks) are offset somewhat by the inaccessibility for repair and generally lower capacity.

2.1.2 Condensers

The condenser removes and dissipates heat from the

compressed vapor to the surrounding air or water to condense the refrigerant vapor to a liquid. The liquid refrigerant then falls by gravity to a receiver (usually located below the condenser), where it is stored and available for future use in the system.

The three basic types of condensers are as follows:

- Air-cooled
- Water-cooled
- Evaporative

The first two are the most common, but the evaporative types are used where low-quality water and its disposal make the use of circulating water-cooled types impractical.

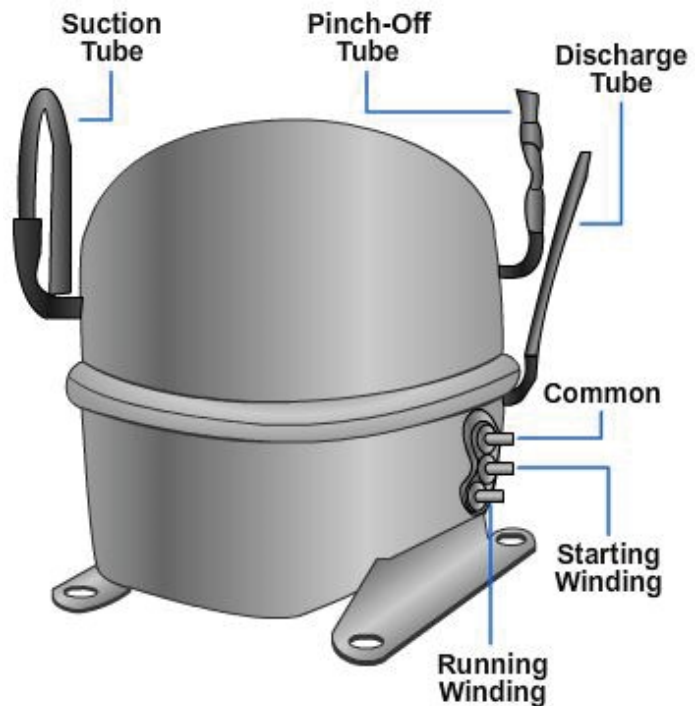

Figure 12-16 – Hermetic compressor.

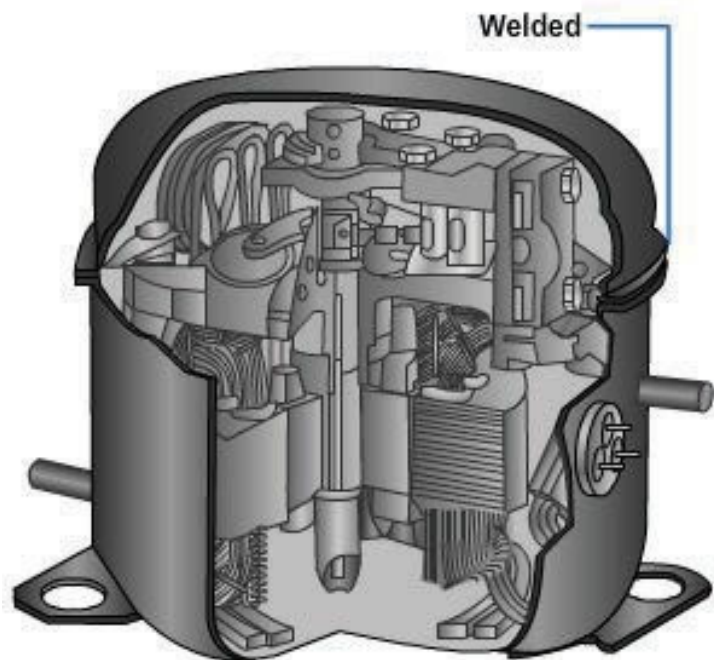

Figure 12-17 – A cutaway view of a hermetic compressor and motor.

2.1.2.1 Air-Cooled Condensers

The construction of air-cooled condensers makes use of several layers of small tubing formed into flat cells. The external surface of this tubing is provided with fins to ease the transfer of heat from the condensing refrigerant inside the tubes to the air circulated through the condenser core around the external surface of the tubes (Figure 12-18).

Condensation takes place as the refrigerant flows through the tubing, and the liquid refrigerant is discharged from the lower ends of the tubing coils to a liquid receiver on the condensing unit assembly.

2.1.2.2 Water-Cooled Condensers

Water-cooled condensers are of the multi-pass shell and tube type, with circulating water

flowing through the tubes. The refrigerant vapor is admitted to the shell and condensed on the outer surfaces of the tubes (Figure 12-19).

The condenser is constructed with a tube sheet brazed to each end of a shell. Copper-nickel tubes are inserted through drilled openings in the tube sheet and are expanded or rolled into the tube sheet to make a gastight seal. Headers, or water boxes, are bolted to the tube sheet to complete the waterside of the condenser. Zinc-wasting bars are installed in the water boxes to minimize electrolytic corrosion of the condenser parts.

A purge connection with a valve is at the top side of the condenser shell to allow manual release of any accumulated air in the refrigerant circuit.

The capacity of the water-cooled condenser is affected by the temperature of the water, quantity of water circulated, and temperature of the refrigerant gas. The capacity of the condenser varies whenever the temperature difference between the refrigerant gas and the water is changed. An increased temperature difference or greater flow of water increases the capacity of the condenser. The use of colder water can cause the temperature difference to increase.

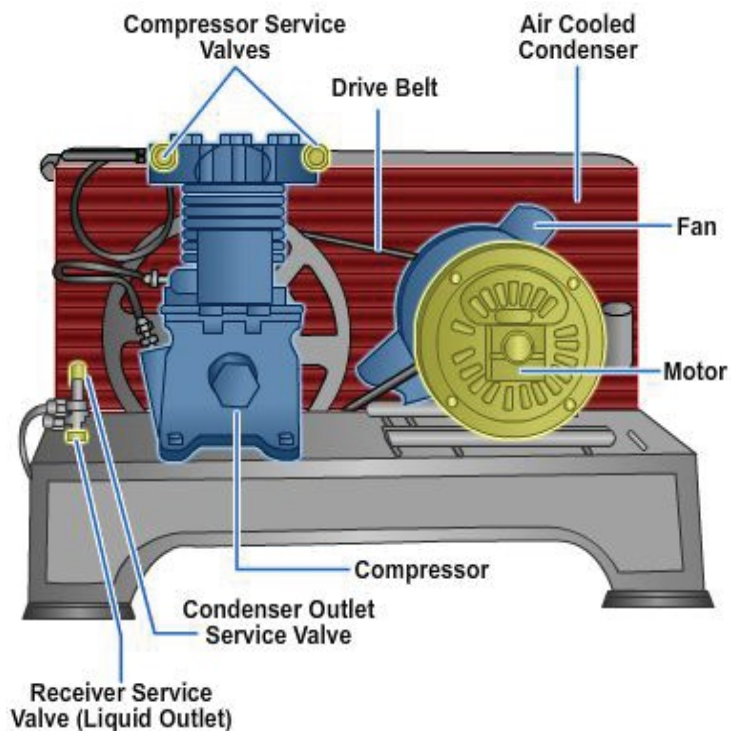

Figure 12-18 - Air-cooled condenser mounted on a compressor unit.

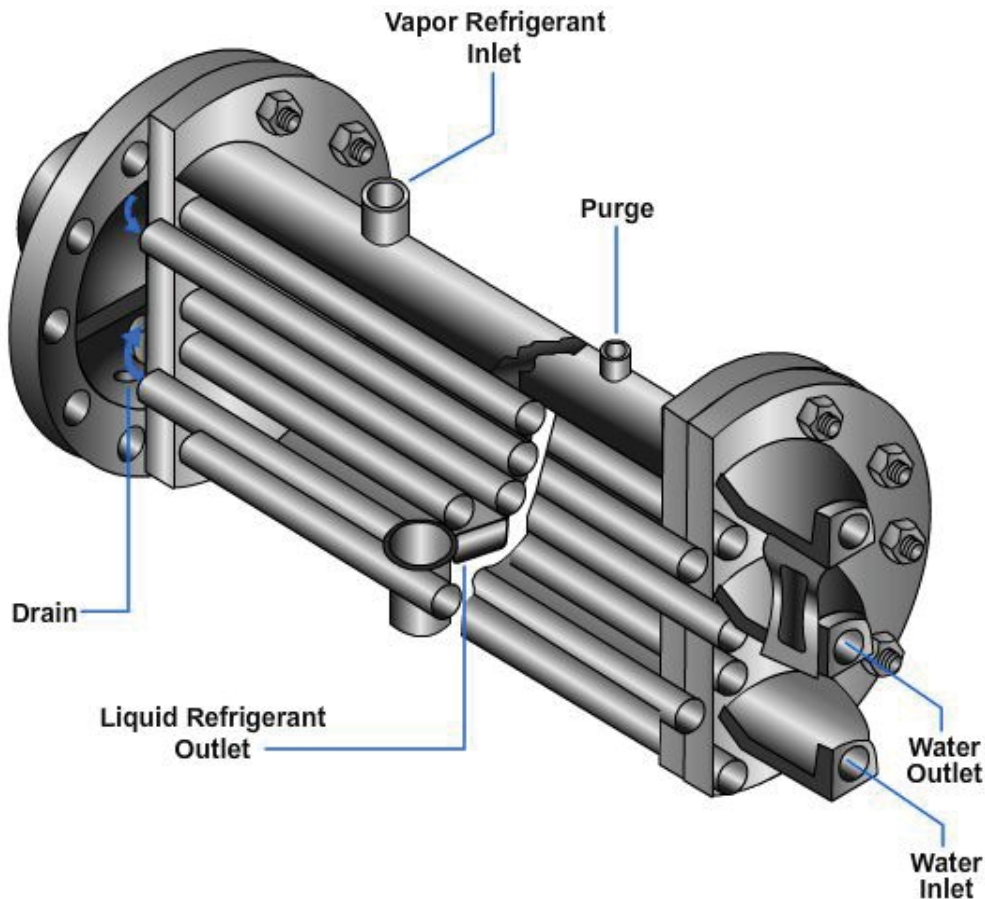

Figure 12-19 –Water-cooled condenser.

2.1.2.3 Evaporative Condensers

An evaporative condenser operates on the principle that heat can be removed from condensing coils by spraying them with water or letting water drip onto them and then forcing air through the coils by a fan.

This evaporation of the water cools the coils and condenses the refrigerant within.

2.1.3 Liquid Receiver

A liquid receiver, as shown in *Figure 12-12*, serves to accumulate the reserve liquid refrigerant, to provide storage for off-peak operation, and to permit pumping down of the system. The receiver also serves as a seal against the entrance of gaseous refrigerant into the liquid line.

When stop valves are provided at each side of the receiver for confinement of the liquid refrigerant, a pressure relief valve is generally installed between the valves in the receiver and condenser equalizing line to protect the receiver against any excessive hydraulic pressure being built up.

2.1.4 Evaporators

The evaporator is a bank or coil of tubing placed inside the refrigeration space. The refrigerant is at a low-pressure and low-temperature liquid as it enters the evaporator.

As the refrigerant circulates through the evaporator tubes, it absorbs its heat of vaporization from the surrounding space and substances. The absorption of this heat causes the refrigerant to boil. As the temperature of the surrounding space (and contents) is lowered, the liquid refrigerant gradually changes to a vapor. The refrigerant vapor then passes into the suction line by the action of the compressor.

Most evaporators are made of steel, copper, brass, stainless steel, aluminum, or almost any other kind of rolled metal that resists the corrosion of refrigerants and the chemical action of the foods.

The two main types of evaporators are dry or flooded. The inside of a dry evaporator refrigerant is fed to the coils only as fast as necessary to maintain the temperature wanted. The coil is always filled with a mixture of liquid and vapor refrigerant. At the inlet side of the coil, there is mostly liquid; the refrigerant flows through the coil (as required); it is vaporized until, at the end, there is nothing but vapor. In a flooded evaporator, the evaporator is always filled with liquid refrigerant. A float maintains liquid refrigerant at a constant level. As fast as the liquid refrigerant evaporates, the float admits more liquid, and, as a result, the entire inside of the evaporator is flooded with liquid refrigerant up to a certain level determined by the float.

The two basic types of evaporators are further classified by their method of evaporation, either direct expanding or indirect expanding. In the direct-expanding evaporator, heat is transferred directly from the refrigerating space through the tubes and absorbed by the refrigerant. In the indirect-expanding evaporator, the refrigerant in the evaporator is used to cool some secondary medium, other than air. This secondary medium or refrigerant maintains the desired temperature of the space. Usually brine, a solution of calcium chloride is used as the secondary refrigerant.

Natural convection or forced-air circulation is used to circulate air within a refrigerated space. Air around the evaporator must be moved to the stored food so that heat can be extracted, and the warmer air from the food returned to the evaporator. Natural convection can be used by installing the evaporator in the uppermost portion of the space to be refrigerated so heavier cooled air will fall to the lower food storage and the lighter food-warmed air will rise to the evaporator. Forced-air circulation speeds up this process and is usually used in large refrigerated spaces to ensure all areas are cooled.

2.1.5 Control Devices

As a UT you should have an understanding of the control devices which are a necessity in a refrigeration system to maintain correct operating conditions.

2.1.5.1 Metering Devices

Metering devices, such as expansion valves and float valves, control the flow of liquid refrigerant between the high side and the low side of the system. These devices are at the end of the line between the condenser and the evaporator. There are five different types: an automatic expansion valve (also known as a constant-pressure expansion valve), a thermostatic expansion valve, low-side and high-side float valves, and a capillary tube.

2.1.5.2 Automatic Expansion Valve

An automatic expansion valve maintains a constant pressure in the evaporator (Figure 12-20). Normally this valve is used only with direct expansion, dry type of evaporators. During operation, the valve feeds the required amount of liquid refrigerant to the evaporator to maintain a constant pressure in the coils. This type of valve is generally used in a system where constant loads are expected. When a large variable load occurs, the valve will not feed enough refrigerant to the evaporator under high load and will over-feed the evaporator at low load. Compressor damage can result when slugs of liquid enter the compressor.

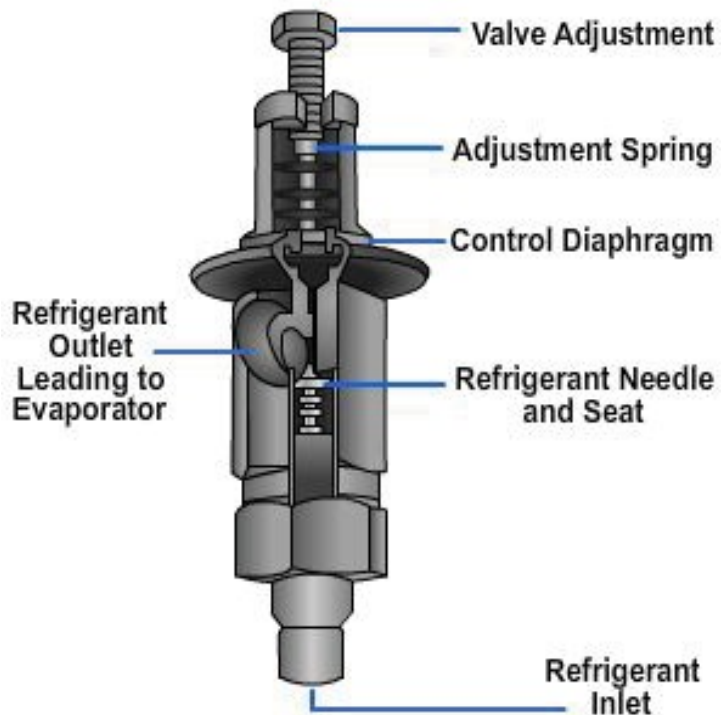

Figure 12-20 – Automatic expansion valve.

2.1.5.3 Thermostatic Expansion Valve

Before discussing the

thermostatic expansion valve, let us explain the term superheat. A vapor gas is superheated when its temperature is higher than the boiling point corresponding to its pressure. When the boiling point begins, both the liquid and the vapor are at the same temperature. But in an evaporator, as the gas vapor moves along the coils toward the suction line, the gas may absorb additional heat and its temperature rises. The difference in degrees between the saturation temperature and the increased temperature of the gas is called superheat.

A thermostatic expansion valve keeps a constant superheat in the refrigerant vapor leaving the coil (Figure 12-21). The valve controls the liquid refrigerant so the evaporator coils maintain the correct amount of refrigerant at all times.

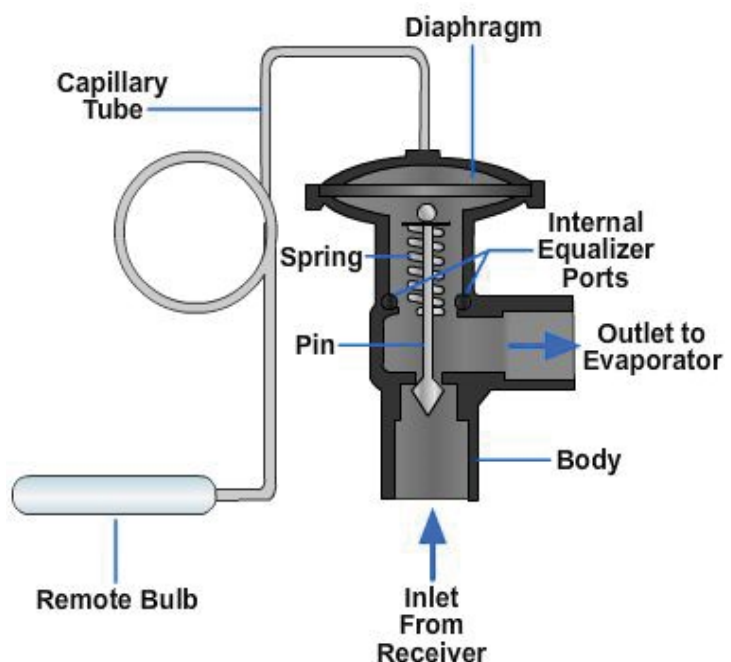

Figure 12-21 - Thermostatic expansion

valve.

The valve has a power element that is activated by a remote bulb located at the end of the evaporator coils. The bulb senses the superheat at the suction line and adjusts the flow of refrigerant into the evaporator.

As the superheat increases at the suction line, the temperature and the pressure in the remote bulb also increase. This increased pressure, applied to the top of the diaphragm, forces it down along with the pin, which opens the valve, admitting replacement refrigerant from the receiver to flow into the evaporator. This replacement has three effects. First, it provides additional liquid refrigerant to absorb heat from the evaporator. Second, it applies higher pressure to the bottom of the diaphragm, forcing it upward, tending to close the valve. And third, it reduces the degree of superheat by forcing more refrigerant through the suction line.

2.1.5.4 Low-Side Float Expansion Valve

The low-side float expansion valve controls the liquid refrigerant flow where a flooded evaporator is used (*Figure 12-22*). It consists of a ball float in either a chamber or the evaporator on the low-pressure side of the system. The float actuates a needle valve through a lever mechanism. As the float lowers, refrigerant enters through the open valve; when it rises, the valve closes.

2.1.5.5 High-Side Float Expansion Valve

In a high-side float expansion valve the valve float is in a liquid receiver or in an auxiliary container on the high-pressure side of the system (*Figure 12-23*).

Refrigerant from the condenser flows into the valve and immediately opens it, allowing

refrigerant to expand and pass into the evaporator. Refrigerant charge is critical. An overcharge of the system floods back and damages the compressor. An undercharge results in a capacity drop.

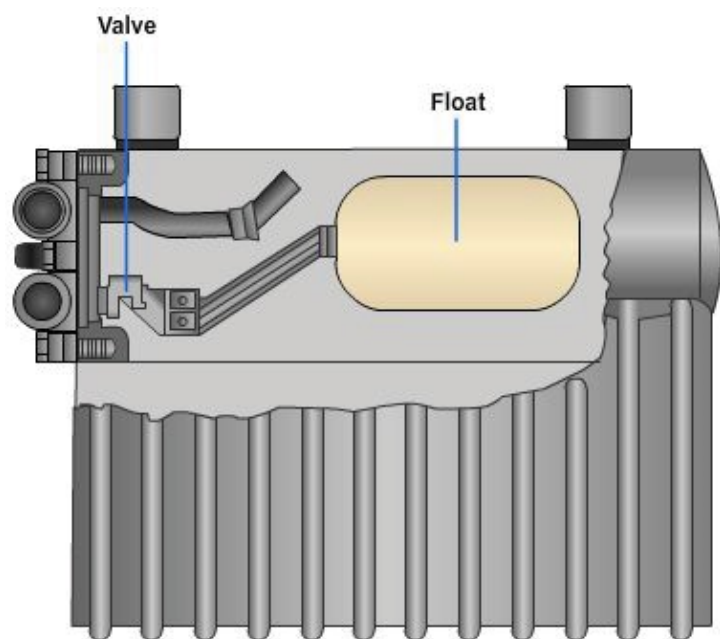

Figure 12-22 - Low-side float expansion valve.

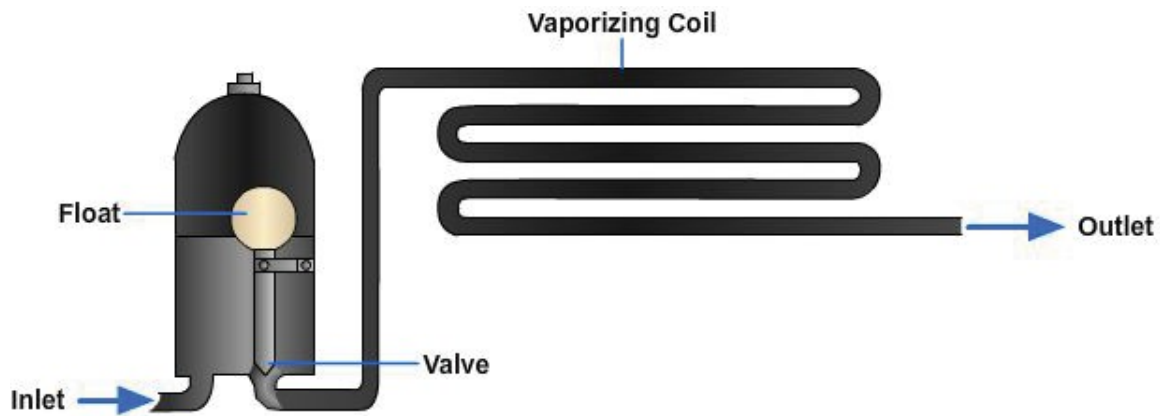

Figure 12-23 – Low-side float expansion valve.

2.1.5.6 Capillary Tube

The capillary tube consists of a long tube of small diameter. It acts as a constant throttle on the refrigerant. The length and diameter of the tube are important; any restrictions cause trouble in the system. It feeds refrigerant to the evaporator as fast as it is produced by the condenser. When the quantity of refrigerant in the system is correct or the charge is balanced, the flow of refrigerant from the condenser to the evaporator stops when the compressor unit stops. When the condensing unit is running, the operating characteristics of the capillary tube-equipped evaporator are the same as if it were equipped with a high-side float. The capillary tube is best suited for household boxes, such as freezers and window air conditioners, where the refrigeration load is reasonably constant and small horsepower motors are used.

2.1.6 Accessory Devices

The four basic or major components of a refrigeration system just described are enough for a refrigeration unit to function. However, you should know that additional devices, such as the receiver already described, make for a smoother and more controlled cycle. Before proceeding, you need to take a close look at *Figure 12-24*, which shows one type of refrigeration system with additional devices installed.

2.1.6.1 Relief Valve

A refrigeration system is a sealed system in which pressures vary. Excessive pressures can cause a component of the system to explode. The National Refrigeration Code makes the installation of a relief valve mandatory. A spring-loaded relief valve is most often used and it is installed in the compressor discharge line between the compressor discharge connection and the discharge line stop valve to protect the high-pressure side of the system. No valves can be installed between the compressor and the relief valve. The discharge from the relief valve is led to the compressor suction line.

2.1.6.2 Discharge Pressure Gauge and Thermometer

A discharge pressure gauge and thermometer are installed in the compressor discharge line (liquid line) to show the pressure and temperature of the compressed refrigerant gas. The temperature indicated on the gauge is always higher than that corresponding to the pressure when the compressor is operating.

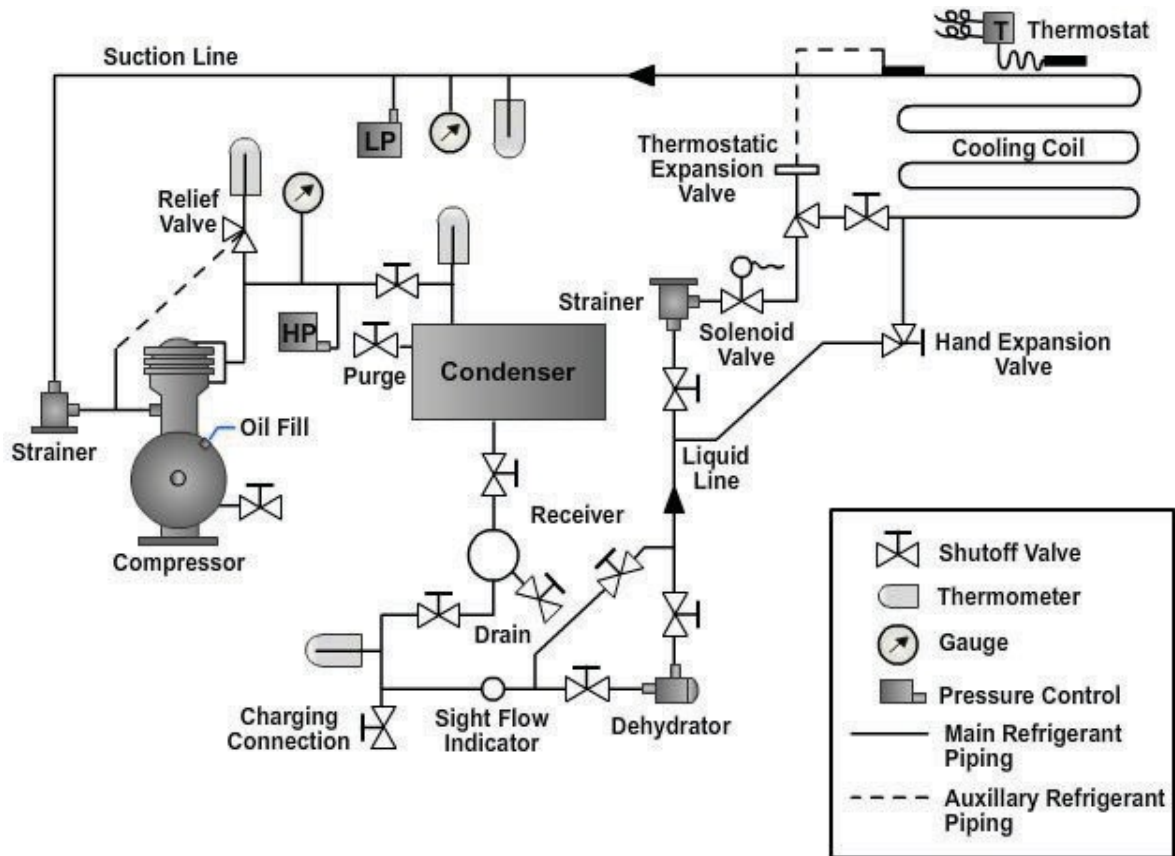

Figure 12-24 – Basic refrigeration system.

2.1.6.3 Compressor Motor Controls

The starting and stopping of the compressor motor are usually controlled by either a pressure-actuated or temperature-actuated motor control. The operation of the pressure motor control depends on the relationship between pressure and temperature. A pressure motor control is shown in Figure 12-25.

The device consists of a low-pressure bellows, or in some cases, a low-pressure diaphragm, connected by a small diameter tube to the compressor crankcase or to the suction line. The pressure in the suction line or compressor crankcase is transmitted through the tube and actuates the bellows or diaphragm. The

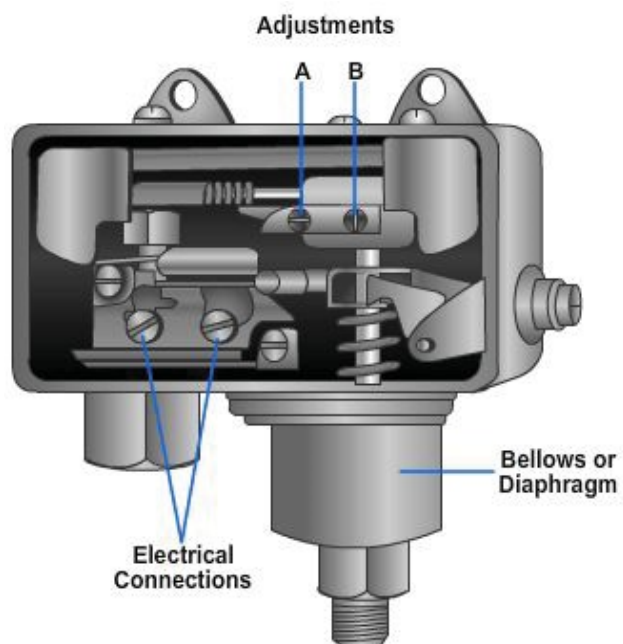

Figure 12-25 - Pressure-actuated motor control.

bellows move according to their pressure, and its movement causes an electric switch to start (cut in) or stop (cut out) the compressor motor.

Adjustments can be made to the start and stop pressures under the manufacturer's instruction. Usually the cutout pressure is adjusted to correspond to a temperature a few degrees below the desired evaporator coil temperature, and the cut-in pressure is adjusted to correspond to the temperature of the coil.

The term pressure-actuated motor control is similar to the pressure device. The main difference is that a temperature-sensing bulb and a capillary tube replace the pressure tube. The temperature motor control cuts in or cuts out the compressor according to the temperature in the cooled space.

The refrigeration system may also be equipped with a high-pressure safety cutout switch that shuts off the power to the compressor motor when the high-side pressure exceeds a preset limit.

2.1.6.4 Solenoid Stop Valves

Solenoid stop valves or magnetic stop valves control gas or liquid flow. They are most commonly used to control liquid refrigerant to the expansion valve but are used throughout the system. The compressor motor and solenoid stop valve are electrically in parallel; that is, the electrical power is applied or removed from both at the same time. The liquid line is open for passage of refrigerant only when the compressor is in operation and the solenoid is energized. *Figure 12-26* shows a typical solenoid stop valve.

Improper operation of these valves can be caused by a burned-out solenoid coil or foreign material lodged between the stem and the seat of the valve, allowing fluid to leak.

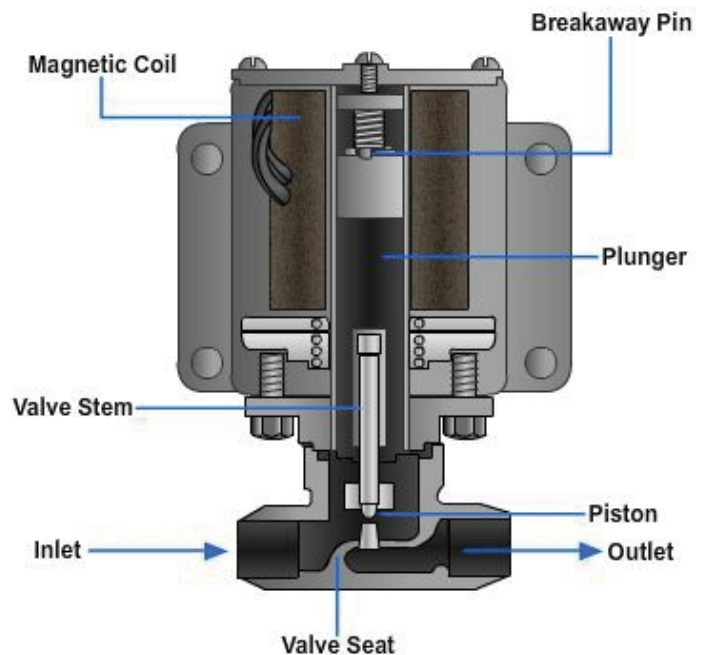

Figure 12-26 – Solenoid stop valve.

Carefully check the valve before replacing or discarding. The valve must be installed so that the coil and plunger are in a true vertical position. When the valve is cocked, the plunger will not reseat properly, causing refrigerant leakage.

2.1.6.5 Thermostat Switch

Occasionally, a thermostat in the refrigerated space operates a solenoid stop valve, and the compressor motor is controlled independently by a low-pressure switch. The solenoid control switch, or thermostat, makes and breaks the electrical circuit, thereby controlling the liquid refrigerant to the expansion valve.

The control bulb is charged with a refrigerant so that temperature changes of the bulb itself produce like changes in pressure within the control bulb. These pressure changes are transmitted through the tubing to the switch power element to operate the switch. The switch opens the contacts releasing the solenoid valve, stopping the flow of refrigerant to the cooling coil when the temperature of the refrigerated space has reached the desired point. The compressor continues to operate until it has evacuated the evaporator. The resulting low pressure in the evaporator then activates the low- pressure switch, which stops the compressor. As the temperature rises, the increase in bulb pressure closes the switch contacts, and the refrigerant is supplied to the expansion valve.

2.1.6.6 Liquid Line

The refrigerant accumulated in the bottom of the receiver shell is conveyed to the cooling coils through the main refrigerant liquid line. A stop valve and thermometer are usually installed in this line next to the receiver. Where the sight-flow indicator, dehydrator, or filter-drier is close to the receiver, the built-in shutoff valves may be used instead of a separate shutoff valve.

2.1.6.7 Liquid Line Filter-Drier or Dehydrator

A liquid line filter-drier prevents or removes moisture, dirt, and other foreign materials from the liquid line that would harm the system components and reduce efficiency (*Figure 12-27*). This tank-like accessory offers some resistance to flow. For this reason, some manufacturers install it in a bypass line. A filter- drier consists of a tubular shell with strainers on the inlet and outlet connections to prevent escape of drying material into the system. Some filter-driers are equipped with a sight-glass indicator, shown in *Figure 12-27*. A dehydrator is similar to a filter-drier, except that it mainly removes moisture.

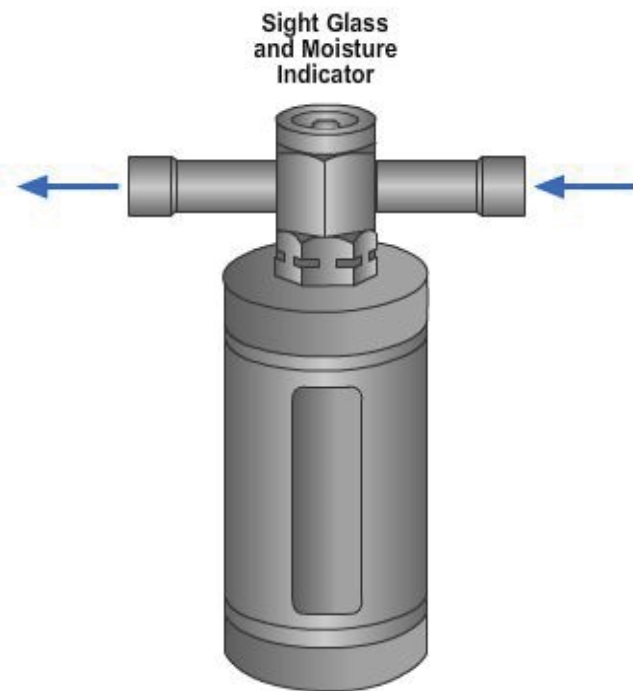

Figure 12-27 –Liquid line filter-drier with sight glass indicator.

2.1.6.8 Sight-Flow Indicator

The sight-flow indicator, also known as a sight glass, is a

special fitting that has a glass (with gasket), single or double port, and seal caps for protection when not in use (*Figure 12-28*). The double-port unit permits the use of a flashlight background. The refrigerant may be viewed passing through the pipe to determine the presence and amount of vapor bubbles in the liquid that would indicate low refrigerant or unfavorable operating conditions. Some filter-driers are equipped with built-in sight-flow indicators and commonly have a color comparison on them to indicate either wet or dry, shown in *Figure 12-28*.

2.1.6.9 Suction Line

Suction pressure regulators are sometimes placed between the outlet of the evaporator and the compressor to prevent the evaporator pressure from being drawn down below a predetermined level despite load fluctuations. These regulators are usually installed in systems that require a higher than normal evaporator temperature.

2.1.6.10 Pressure Control Switches

Pressure control switches, often called low-pressure cutouts, are essentially a single-pole, single-throw electrical switch and are mainly used to control starting and stopping of the compressor (Figure 12-29). The suction pressure acts on the bellows of the power element of the switch and produces movement of a lever mechanism operating electrical contacts. A rise in pressure closes the switch contacts completing the motor controller circuit, which automatically starts the compressor. As the operation of the compressor gradually decreases the suction pressure, the movement of the switch linkage reverses until the contacts are separated at a predetermined low-suction pressure, thus breaking the motor controller circuit and stopping the compressor.

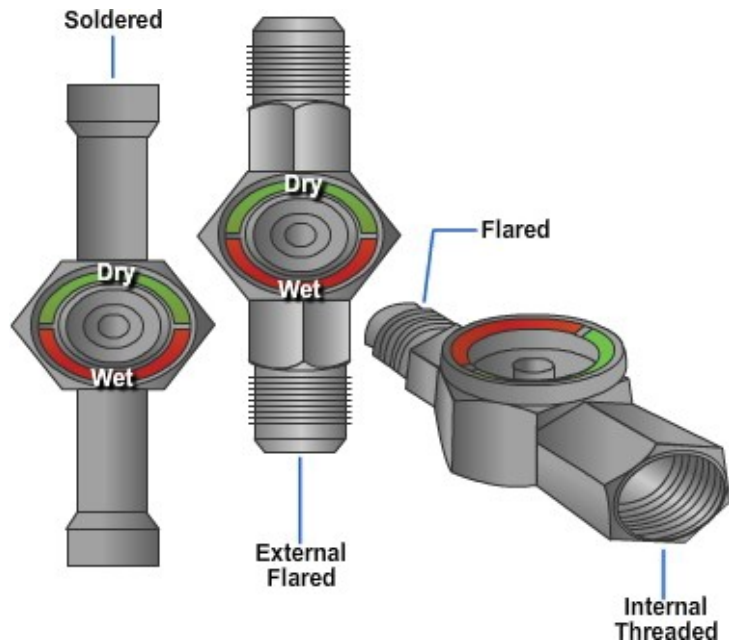

Figure 12-28 - Sight-flow indicators with different types of connections.

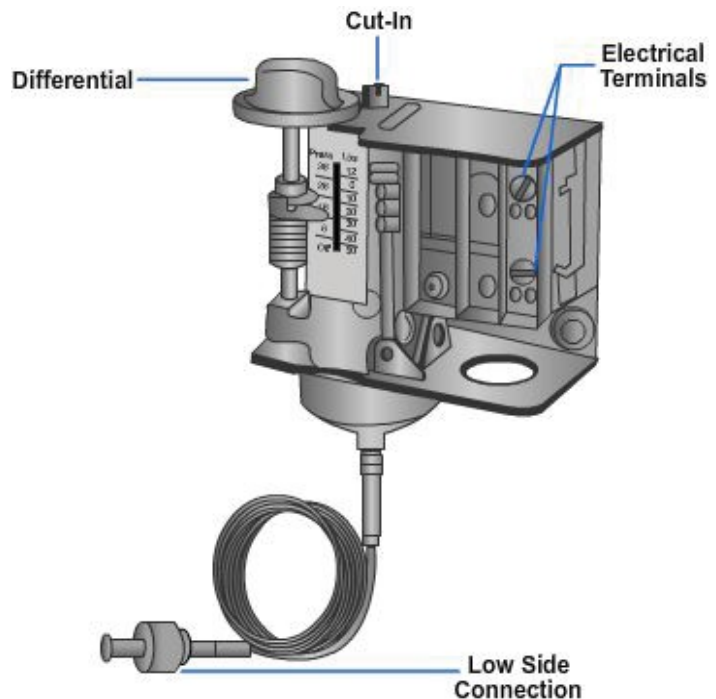

Figure 12-29 - Pressure type cut-in, cutout control switch.

2.1.6.11 Suction Line Filter-Drier

Some systems include a low-side filter-drier at the compressor end of the suction line (*Figure 12-30*).

The filter-drier used in the suction line should offer little resistance to flow of the vaporized refrigerant, as the pressure difference between the pressure in the evaporator and the inlet of the compressor should be small.

These filter-driers function to remove dirt, scale, and moisture from the refrigerant before it enters the compressor.



Figure 12-30 – Suction line filter-drier.

2.1.6.12 Gauges and Thermometers

Between the suction line stop valve and the compressor, a pressure gauge and thermometer may be provided to show the suction conditions at which the compressor is operating. The thermometer shows a higher temperature than the temperature corresponding to the suction pressure indicated on the gauge, because the refrigerant vapor is superheated during its passage from the evaporator to the compressor.

2.1.6.12 Accumulators and Oil Separators

Liquid refrigerant must never be allowed to enter the compressor. Liquids are non-compressible; in other words, their volume remains the same when compressed. An accumulator is a small tank safety device designed to prevent liquid refrigerant from flowing into the suction line and into the compressor (*Figure 12-31*). A typical accumulator has an outlet at the top. Any liquid refrigerant that flows into the accumulator is evaporated, and then the vapor will flow into the suction line to the compressor.

Oil from the compressor must not move into the rest of the refrigeration system. Oil in the lines and evaporator reduces the efficiency of the system. An oil separator is located between the compressor discharge and the inlet of the condenser (*Figure 12-32*). The oil separator consists of a tank or cylinder with a series of baffles and screens which collect the oil. This oil settles to the bottom of the separator. A float arrangement operates a needle valve, which opens a return line to the compressor crankcase.

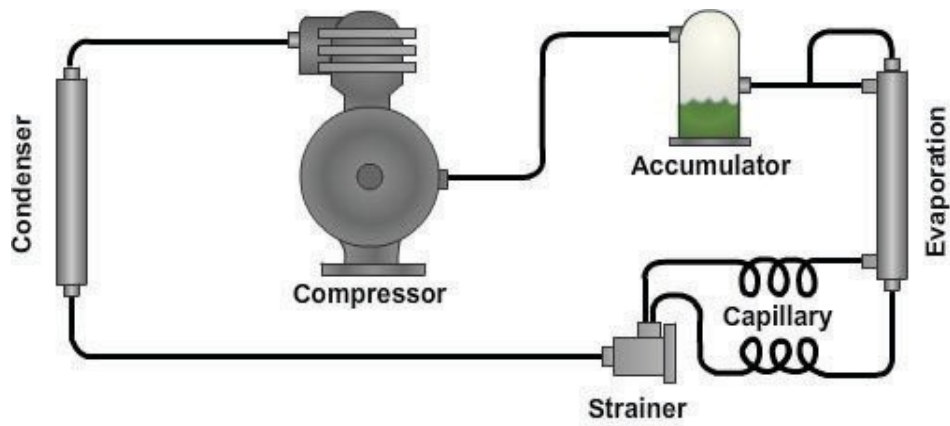

Figure 12-31 –Accumulator location.

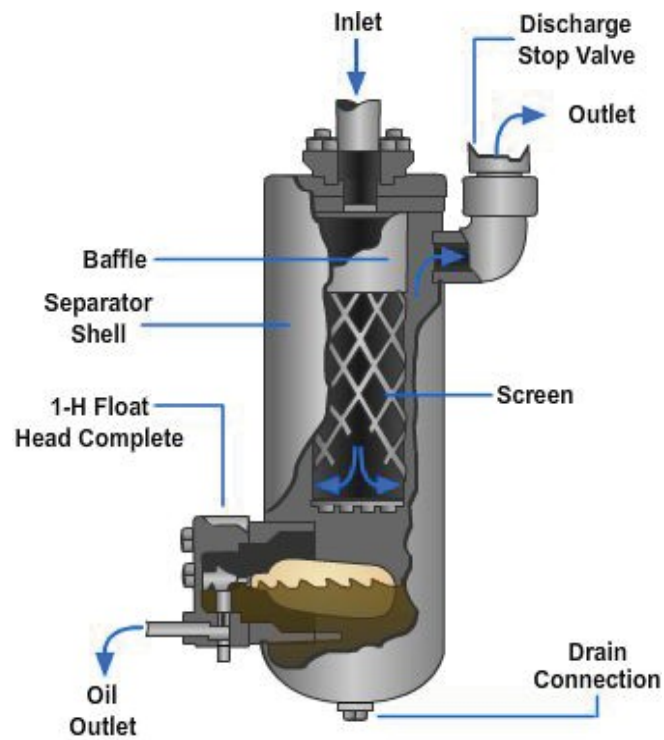

Figure 12-32 –Cutaway view of an oil separator.

Test your Knowledge (Select the Correct Response)

2. Which expansion valve controls the liquid refrigerant flow where a flooded evaporator is used?
 - A. Thermostatic
 - B. Low-side
 - C. High-side
 - D. Automatic

3. Which accessory device consists of a low-pressure bellows or a low-pressure diaphragm connected by a small diameter tube to the compressor?
- A. Compressor-motor control
 - B. Relief valve
 - C. Solenoid stop valve
 - D. Suction line

3.0.0 REFRIGERANTS

A refrigerant is a compound used in a heat cycle that reversibly undergoes a phase change from a gas to a liquid. Traditionally, fluorocarbons (FC), especially chlorofluorocarbons (CFC) were used as refrigerants. Other refrigerants are air, water ammonia, sulfur dioxide, carbon dioxide, and non-halogenated hydrocarbons such as methane.

The ideal refrigerant has good thermodynamic properties, is unreactive chemically, and is safe. The desired thermodynamic properties are a boiling point somewhat below the target temperature, a high heat of vaporization, and moderate density in liquid form, a relatively high density in gaseous form, and high critical temperature.

Since boiling point and gas density are affected by pressure, refrigerants may be made more suitable for a particular application by choice of operating pressure.

3.1.0 R-12 Dichlorodifluoromethane (CCl₂F₂)

For decades R-12, which is a **chlorofluorocarbon**, was a primary refrigerant for refrigerators and air-conditioning systems. In 1996, however, the production of R-12 in the United States was banned due to a 1992 international environmental agreement to phase out all ozone-depleting CFCs.

Even though production of R-12 is no longer legal in the U.S., it is important for you, as a UT, to know that R-12 is still used in some older refrigeration systems. That means when it is time to change the refrigerant in an existing system, you will have to replace or retrofit the parts of the system to accommodate the new refrigerant.

3.2.0 R-22 Monochlorodifluoromethane (CHClF₂)

The R-22 refrigerant is a **hydrochlorofluorocarbon** (HCFC). It is a synthetic refrigerant developed for refrigeration systems that need a low-evaporating temperature. This explains its extensive use in household refrigerators and window air conditioners. R-22 is nontoxic, noncorrosive, nonflammable, and has a boiling point of -41°F at atmospheric pressure. R-22 can be used with reciprocating or centrifugal compressors. Water mixes readily with R-22, so larger amounts of desiccant are needed in the filter-driers to dry the refrigerant.

3.3.0 R-502 Refrigerant (CHClF₂/CClF₂CF₃)

R-502 is an **azeotropic** mixture of 48.8 percent R-22 and 51.2 percent R-115. Azeotropic refrigerants are liquid mixtures of refrigerants that exhibit a constant maximum and minimum boiling point. These mixtures act as a single refrigerant. R-502 is noncorrosive, nonflammable, practically nontoxic, and has a boiling point of -50°F at atmospheric pressure. This refrigerant can be used only with reciprocating compressors. It is most often used in refrigeration applications for commercial frozen food equipment, such as walk-in refrigerators, display cases, and processing plants.

3.4.0 R-134a Tetrafluoroethane (CH₂FCF₃)

R-134a refrigerant is a *hydrofluorocarbon* (HFC). It is very similar to R-12, but has no harmful influence on the ozone layer. R-134a has become a replacement for R-12 because it is noncorrosive, nonflammable, and nontoxic, and has a boiling point of -15°F at atmospheric pressure. Used for medium-temperature applications, such as air conditioning and commercial refrigeration, this refrigerant is now used in automobile air-conditioners.

3.5.0 R-717 Ammonia (NH₃)

R-717 ammonia is commonly used in industrial systems. It has a boiling point of -28°F at atmospheric pressure. This property makes it possible to have refrigeration at temperatures considerably below zero without using pressure below atmospheric in the evaporator. Normally it is a colorless gas, is slightly flammable, and, with proper portions of air it can form an explosive mixture, but accidents are rare.

3.6.0 R-125 Pentafluoroethane (CHCF₅)

The R-125 refrigerant is a blend component used in low- and medium-temperature applications. It has a boiling point of -55.3°F at atmospheric pressure. R-125 is nontoxic, nonflammable, and noncorrosive. R-125 is one replacement refrigerant for R-502.

3.7.0 R-410A Refrigerant

R-410A is a near-azeotropic mixture of R-32 and R-125 and is used as a refrigerant in air conditioning applications. Unlike many *haloalkane* refrigerants it does not contribute to ozone depletion, and is recognized by the EPA as an acceptable substitute for R-22. However, it has a high global warming potential of 1725 (1725 times the effect of carbon dioxide), similar to that of R-22.

3.8.0 Ozone Protection and the Clean Air Act

In 1987 the Montreal Protocol, an international environmental agreement, established requirements that began the worldwide phase-out of ozone-depleting CFCs. These requirements were later modified, leading to the phase-out in 1996 of CFC production in all developed nations, including the U.S.

In 1992 the Montreal Protocol was amended to establish a schedule for the phase-out of HCFCs. HCFCs are less damaging to the ozone layer than CFC, but still contain ozone-destroying chlorine. The Montreal Protocol, as amended, is carried out in the U.S. through the Title IV of the Clean Air Act, which is implemented by the Environmental Protection Agency (EPA).

After 2010, manufacturers will no longer be able to produce, and companies will no longer be able to import the HCFC R-22 for use in new air-conditioning systems.

However, they will be able to produce and import R-22 for use in servicing existing equipment until 2020. The international agreement also calls for the elimination of all HCFCs by 2030.

Test your Knowledge (Select the Correct Response)

4. Which refrigerant has become a replacement for R-12 because it is noncorrosive, nonflammable, practically nontoxic, and has a boiling point of -50°F at atmospheric pressure?
- A. R-502
 - B. R-134a
 - C. R-125
 - D. R-22
5. In what year was the Montreal Protocol amended to establish a schedule for the phase-out of HCFCs?
- A. 1987
 - B. 1992
 - C. 1990
 - D. 1996

4.0.0 REFRIGERANT SAFETY

As a UT you are required to adhere to all safety standards. Safety is always paramount and this is especially true when working with refrigerants. It is important to remember that following the required safety standards is not only for your safety, but also for the safety of your fellow technicians.

4.1.0 Personal Protection

Since R-22, R134a, R-125, and R-410A are nontoxic, you will not have to wear a gas mask; however, you must protect your eyes by wearing splash-proof goggles to guard against liquid refrigerant freezing the moisture of your eyes. When liquid R-22, R-134a, R-125, or R-410A, contacts the eyes, make sure the injured person gets to medical as soon as possible. Avoid rubbing or irritating the eyes. Give the following first aid immediately:

- Drop sterile mineral oil into the eyes and irrigate them.
- Wash the eyes during the irrigation with a weak boric acid solution or a sterile salt solution that does not exceed 2 percent salt.

Should the refrigerant contact the skin, flush the affected area repeatedly with water. Strip refrigerant-saturated clothing from the body, wash the skin with water, and take the patient immediately to the dispensary. Should a person have a hard time breathing in a space which lacks oxygen due to a high concentration of refrigerant, provide assistance to the individual by administering artificial respiration.

4.2.0 Handling and Storage of Refrigerant Cylinders

The procedures for handling and storing refrigerant cylinders are similar to those of any other type of compressed gas cylinders. When handling and storing cylinders, keep the following rules in mind:

- Open valves slowly; never use any tools except those approved by the manufacturer.

- Keep the cylinder cap on the cylinder unless the cylinder is in use.
- When refrigerant is discharged from a cylinder, immediately weigh the cylinder.
- Record the weight of the refrigerant remaining in the cylinder.
- Ensure only regulators and pressure gauges designed for the particular refrigerant in the cylinder are used.
- Do NOT use different refrigerants in the same regulator or gauges.
- Never drop the cylinders or permit them to strike each other violently.
- Never use a lifting magnet or a sling. A crane may be used when a safe cradle is provided to hold the cylinders.
- Never use cylinders for any other purpose than to carry refrigerants.
- Never tamper with safety devices in the cylinder valves.
- Never force connections that do not fit. Ensure the cylinder valve outlet threads are the same as what is being connected to it.
- Never attempt to alter or repair cylinders or valves.
- Cylinders stored in the open must be protected from extremes of weather and direct sunlight. A cylinder should never be exposed to temperature above 120°F.
- Store full and empty cylinders apart to avoid confusion.
- Never store cylinders near elevators or gangways.
- Never store cylinders near highly flammable substances.
- Never expose cylinders to continuous dampness, salt water, or spray.

Test your Knowledge (Select the Correct Response)

6. How often should you weigh a refrigerant cylinder?
- A. Twice daily
 - B. Every time refrigerant is discharged
 - C. Only after the first discharge of refrigerant
 - D. Once per day
7. **(True or False)** Goggles are not required when working with refrigerants.
- A. True
 - B. False

5.0.0 REFRIGERANT EQUIPMENT

The equipment used for refrigeration can be classified as either self-contained or remote units. Self-contained equipment houses both the insulated storage compartments (refrigerated), in which the evaporator is located, and a non-insulated compartment (non-refrigerated), in which the condensing unit is located, in the same cabinet. This type of equipment can be designed with a hermetically sealed, semi-sealed, or an open condensing unit. These units are completely assembled and charged at the factory and come ready for use with little or no installation work.

Self-contained refrigerating units include the following types of equipment:

- Domestic refrigerators and freezers
- Water coolers
- Reach-in and walk-in refrigerators
- Small cold-storage plants
- Ice plants

Remote refrigerating equipment has the condensing unit installed in a remote location from the main unit. These types of units are used where the heat liberated from the condenser cannot enter the space where the unit is installed or space is limited for installation.

5.1.0 Reach-In Refrigerators

Reach-in refrigerators have a storage capacity of 15 cubic feet or greater. They are used at Navy installations to store perishable foods in galleys and messes. Navy hospitals and medical clinics also use them to store biologicals, serums, and other medical supplies that require temperatures between 30°F and 45°F. The most frequently used are standard-size units with storage capacities between 15 and 85 cubic feet. *Figure 12-33* shows a typical reach-in refrigerator with a remote (detached) condensing unit.

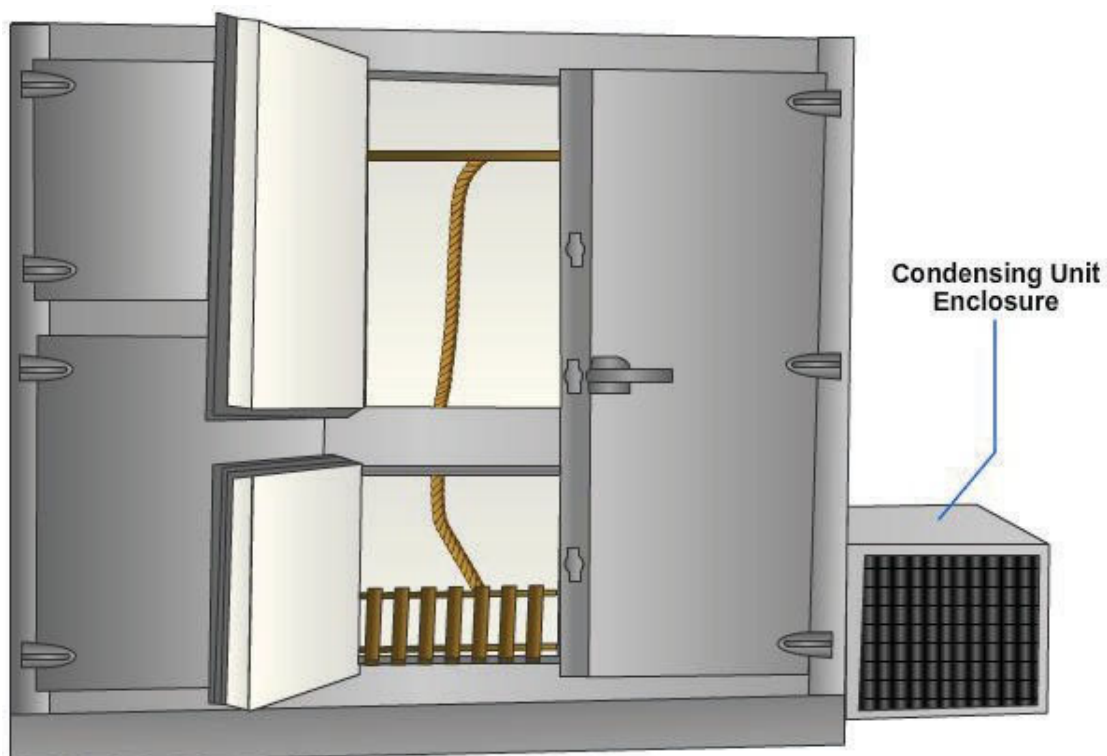

Figure 12-33 – Reach-in refrigerator with a remote condensing unit.

The exterior finishes for reach-in refrigerators are usually of stainless steel, aluminum, or vinyl, while the interior finishes are usually metal or plastic. The refrigerator cabinet is insulated with board or batten type polystyrene or urethane. Reach-in refrigerators are normally self-contained, with an air-cooled condenser. Water-cooled condensers are sometimes used in larger refrigerators with remote condensers.

A typical self-contained unit is shown in *Figure 12-34*. The evaporator is mounted in the center of the upper portion of the food compartment. In operation, warm air is drawn by the fan into the upper part of the unit cooler, where it passes over the evaporator coils, is cooled, and then is discharged at the bottom of the cooler. The air then passes up through the interior and around the contents of the refrigerator.

The cycle is completed when the air again enters the evaporator. The low-pressure control is set to operate the evaporator on a self-defrosting cycle, and temperature is thus controlled. Another type of control system uses both temperature and low-pressure control or defrost on each cycle. The evaporator fan is wired for continuous operation within the cabinet.

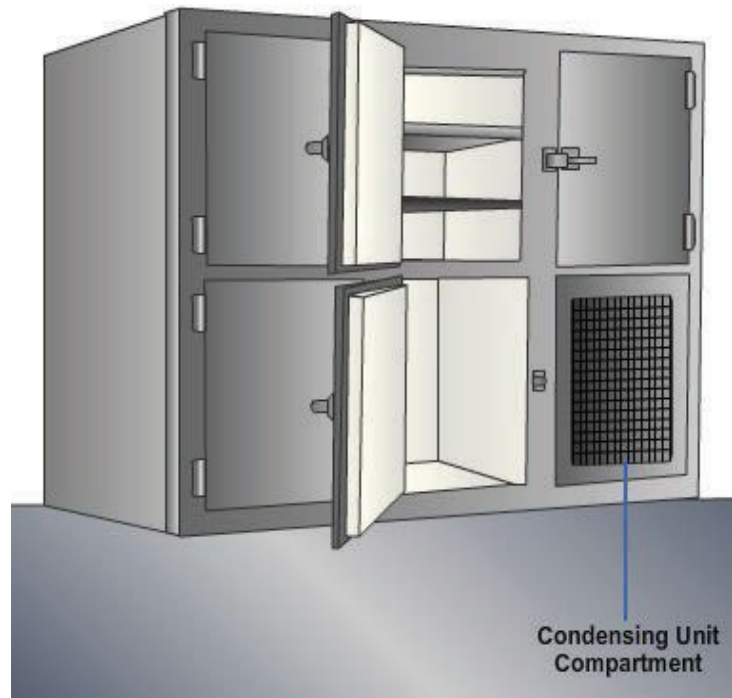
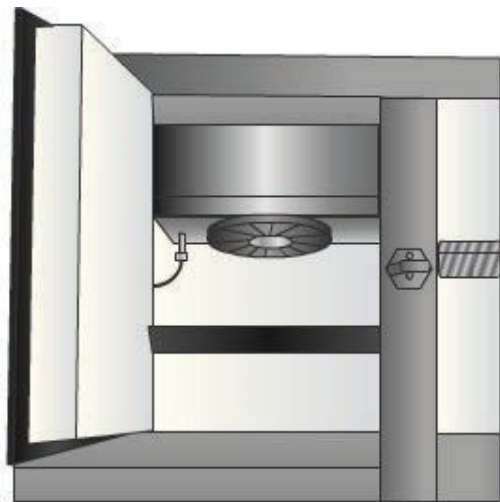
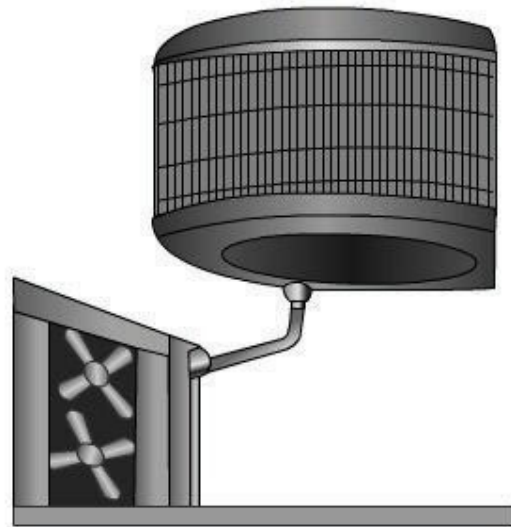

Figure 12-34 - Self-contained reach-in refrigerator.

Evaporators in reach-in refrigerators are generally the unit cooler type with dry coils (*Figure 12-35*). In smaller capacity refrigerators, ice-making coils, similar to those used in domestic refrigerators, are often used as well as straight gravity coils.



Unit Type Cooler



Dome Type Cooler

Figure 12-35 – Unit and dome coolers used in reach-in refrigerators.

5.2.0 Walk-In Refrigerators

Walk-in refrigerators are normally larger than reach-in types and are either built-in or pre-fabricated sectional walk-in units. They are made in two types—one for bulk storage of fresh meats, dairy products, vegetables, and fruits requiring a temperature from 35°F to 38°F and the other for the storage of frozen food at temperatures of 10°F or below. The 35°F to 38°F refrigerators are built and shipped in sections and assembled at the location where they are installed. They can be taken apart, moved, and reassembled in another area if needed. Standard-size coolers can be from 24 square feet up to 120 square feet in floor area. A walk-in refrigerator with reach-in doors is shown in *Figure 12-36*.

Normally, the exteriors and interiors of walk-in refrigerators are galvanized steel or aluminum. Vinyl, porcelain, and stainless steel are also used. Most walk-in refrigerators use rigid polyurethane board, batten, or foamed insulation between

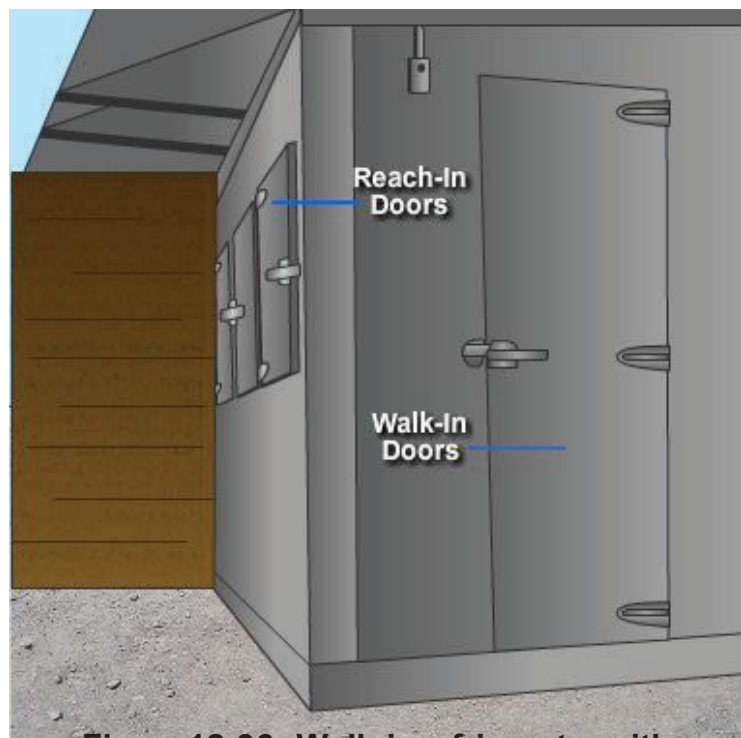

Figure 12-36 – Walk-in refrigerator with reach-in doors.

the inner and outer walls. Insulation 3 to 4 inches in thickness is generally used for storage temperatures between 35°F to 40°F. For low-temperature applications, 5 inches or more of insulation is used. These refrigerators are equipped with meat racks and hooks to store meat carcasses. Walk-in refrigerators also have a lighting system inside the refrigerator compartment. Most systems have the compressor and condenser outside the main structure and use either a wall-mounted forced-air or gravity-type evaporator that is separated from the main part of the cabinet interior by a vertical baffle.

The operation of walk-in and reach-in refrigerators is similar. The evaporator must have sufficient capacity (Btu per hour) to handle the heat load from infiltration and product load.

5.3.0 Domestic Refrigerators

Domestic refrigerators are used in most facilities on a Navy installation. Most domestic refrigerators are of two types-either a single door fresh food refrigerator or a two-door refrigerator-freezer combination, with the freezer compartment on the top portion of the cabinet, or a vertically split cabinet (side-by-side), with the freezer compartment on the left side of the cabinet. They are completely self-contained units and are easy to install. Most refrigerators use R-22 refrigerant, which maintains temperatures of 0°F in the freezer compartment and about 35°F to 45°F in the refrigerator compartment.

As a UT, you must be able to perform maintenance and repair duties of domestic refrigerators, water coolers, and ice machines at Navy activities. This section provides information that will aid you when performing troubleshooting duties. However, you need to remember that the information provided is intended as a general guide, and should be used along with the manufacturer's detailed instructions. For troubleshooting guidance, see *Table 12-3*.

Table 12-3 – Troubleshooting Checklist for Domestic Refrigerators and Freezers.

Trouble	Possible Causes	What to look for and what to do
1. Unit fails to start	Wiring	Loose connections, broken wires, ground leads, open contacts, blown fuses, poor plug contacts, poorly soldered connections. Correct defects found.
	Low voltage	Rated voltage should be \pm 10 percent. Overloaded circuits; read the voltage across the compressor-motor terminals; if it reads 100 volts or under, the circuit is overloaded. Check the voltage at the fuse panel; if this voltage is low, the power supply voltage needs correction. Provide a separate circuit for the unit.
	Compressor motor	Remove leads from the compressor motor. Apply 115 volts to the motor running winding terminals on the terminal plate from a separate two-conductor cable. Then, touch a jumper wire across both the starting and the running winding terminals. If the motor starts and runs, the trouble is isolated in the control or in the compressor motor thermostat. If the motor does not start, replace it.
	Motor thermostat	Connect a jumper to shunt the thermostat from the line-side terminal of the thermostat across to the common terminal of the compressor motor. If the compressor starts, the thermostat is open and should be replaced. Do not attempt to correct calibration of the thermostat. Replace the thermostat.
2. Unit runs normally but temperature is too high	Temperature selector control set too high	Reset the dial to its normal position.
	Temperature control out of adjustment	Readjust the control in accordance with the manufacturer's instructions.
	Poor air circulation in the cabinet	Paper on shelves; too much food in storage; other obstructions to proper air circulation. Maintain sufficient space in the cabinet for proper air circulation.
	Damper control faulty	On models with this type of control it is best to replace the control or to follow the manufacturer's instructions.
3. Unit runs normally but temperature is too low	Temperature selector control out of adjustment	Reset the control to a higher position.
	Temperature control out of adjustment	Readjust the control in accordance with the manufacturer's instructions.
4. Unit runs too long and temperature is too low	Temperature bulb improperly located or defective	Replace or relocate the bulb in accordance with the manufacturer's instructions. Be sure the bulb is securely attached to the evaporator. Replace defective bulbs.
	Compressor	Refer to item 7.

Table 12-3 - Troubleshooting Checklist for Domestic Refrigerators and Freezers (cont.).

Trouble	Possible Causes	What to look for and what to do
5. Unit does not run and temperature is too high	No power at outlet	Check the fuses. If any are burned-out, replace them.
	Poor plug contact	Spread the plug contacts.
	Temperature control inoperative	Examine the control main contacts; clean them with a magneto file or with fine sandpaper; replace them if they are badly burned or pitted. Do not use emery cloth. Check and replace the relay assembly, if necessary. If the temperature control main contacts are found open, try warming the temperature control bulb by hand. If this does not close the control contacts, the control bellows has lost its charge, and the control should be replaced.
	Pressures in system not equalized	Wait for a period of about 5 minutes before trying to restart the unit. See item 3.
	Open circuit in wiring	Make voltmeter or test-lamp checks to determine whether any part of the electrical wiring system is open, or any controls are inoperative. Correct defective connections, and replace worn or damaged controls.
	Compressor thermostat open	See item 1.
	Open motor windings	See item 1.
6. Unit runs for short periods; temperature too high	Defroster heater	On a unit equipped with a defrosting heater, check the defrosting cycle in accordance with the manufacturer's instructions. Ascertain whether the defrosting heater is turned off by making sure that no current flows through it during the refrigerating cycle.
	Unit operates on thermostat	See item 9.
7. Unit runs continuously; temperature too high	Moisture, obstruction, or restriction in liquid line	Before checking for moisture, be certain that the symptoms observed are not caused by improper operation of the defrosting heater, if so equipped. These heaters are wired into the cabinet wiring so that the control contacts short out the heaters when the contacts are closed. Thus the heaters are on only if the machine is off, when the control contacts open, and the evaporator is on the defrost cycle. Check the control contacts to see that the defrosting heaters are off when the machine is running. At high ambient temperature the unit will cycle on its thermostat. The evaporator will warm up over its entire surface if the liquid circulation is completely obstructed. If partly obstructed, part of the frost on the evaporator will melt. Under these conditions, the unit will probably operate noisily, and the motor will tend to draw a heavy current. If the liquid line is obstructed by ice, it will melt after the unit has warmed up. The unit will then refrigerate normally. If this obstruction occurs frequently and spare units are available, replace the unit.

Table 12-3 - Troubleshooting Checklist for Domestic Refrigerators and Freezers (cont.).

Trouble	Possible Causes	What to look for and what to do
7. Unit runs continuously; temperature too high (cont.)	Broken valves	Exceedingly high current to the motor. No cooling in the evaporator and no heating in the condenser. Excessive compressor noise. Replace the hermetic compressor or replace the valves in an open-type compressor.
	Clogged tubing	Check the tubing for damage, sharp bends, kinks, pinches, etc. Straighten the tubing, if possible, or replace the unit.
	Refrigerant leaks or is under-charged	The unit may tend to run normally but more frequently. The evaporator becomes only partly covered with frost. The frost will tend to build up nearest to the capillary tube while the section nearest to the suction line will be free from frost. As leakage continues, the frost line will move back across the evaporator. When the refrigerant is entirely gone, no refrigeration will occur. Units with large evaporators will not frost up unless the evaporator is mounted inside of the box. Test for leaks with a halide leak detector. Recharge the unit, if necessary.
	Cabinet light	Check the operation of the light switch. See that the light goes out as the door is closed.
	Air circulation	See that sufficient space is allowed for air circulation. Relocate or reposition the unit, if possible.
	Evaporator needs defrosting	Advise the user on defrosting instructions.
	Gasket seals	Give them a thorough cleaning. If worn they should be replaced.
	Ambient temperature	Relocated the unit in a location where the ambient temperature ranges from 55 degrees to 95 degrees.
	Defroster heater	On units so equipped, check the defroster heater circuit. See item 6.
	Compressor suction valve sticks open or is obstructed by corrosion or dirt	Ascertain whether the condenser gets warm, and check the current drawn by the motor. If the condenser does not get warm and the current drawn is low, disassemble the compressor (open type) and check the action of the suction valve.
	Compressor discharge valve sticks open or is obstructed	Connect the test gauge assembly and run the unit until the low-side pressure is normal. With an ear in close proximity to the compressor, listen for a hissing sound of escaping gas past the discharge valve. The low-side pressure gauge will rise, and the high side will drop equally until both are the same. Clean out obstructions.

Table 12-3 - Troubleshooting Checklist for Domestic Refrigerators and Freezers (cont.).

Trouble	Possible Causes	What to look for and what to do
8. Unit runs too long; temperature too high	Condenser	Check for any obstruction in the path of air circulation around the condenser. Clean any dust accumulation.
	Fan	On units so equipped, check to see that the fan blades are free to turn and that the fan motor operates.
	Door seal	Clean seals around the door. Check closure of the door with a strip of paper between the gasket and the cabinet at all points around the door. The gasket should grip the paper tightly at all points.
	Refrigerant	Check for leakage and undercharge of the refrigerant. See item 7.
	Usage	Warn the user against too frequent opening of the door, storage of hot foods, heavy freezing loads, and other improper usage.
9. Unit operates on thermostat; temperature too high	Voltage	Check voltage \pm 10 percent of rating.
	Defrosting heater	See that the defrosting heater is turned off.
	Starting relay	Determine that the starting relay does not stick closed. Follow the manufacturer's instructions on methods of checking.
	Condenser	Check the air circulation around the condenser; also check the operation of the fan.
	Pressure not equalized	Wait 5 minutes after stopping, then restart; turn to the coldest position, then to the normal position.
	Restrictions in liquid line	See item 7.
	Thermostat	Thermostat may be out of calibration. Replace the thermostat.
	10. Noisy operation	Fan blades
Fan motor		Check the motor mounting and tighten the connection.
Tube rattling		Adjust the tubes so that they do not rub together.
Food shelves		Adjust them to fit tightly.
Compressor		Malfunctioning valves; loose bolted connections; improper alignment of open-type compressor. Replace the hermetic compressor tighten the connections; realign the open-type compressor.

Table 12-3 - Troubleshooting Checklist for Domestic Refrigerators and Freezers (cont.).

Trouble	Possible Causes	What to look for and what to do
10. Noisy operation (cont.)	Floor or walls	Check to see that the floor is rigid, and whether the walls vibrate. Locate and correct any such sources of noise. Make corrections by bolting or nailing loose portions to structural members.
	Belt	Check the condition of the motor belt. Replace it when it becomes worn or frayed.
11. Unit uses too much electricity	Door	Check the door seal. See item 7.
	Usage	Instruct the user on proper usage of the motor. See item 8. Check the overload.
	Ambient temperature too high	See item 7. The unit will operate more frequently and over longer periods of time in a high-temperature atmosphere. Correct, if possible, by changing the location of the unit.
	Defrost control	Check the defrost circuit according to the manufacturer's instructions.
	Temperature control	Selector control dial set too low. Advise the user. Operate it as near to the "Normal" setting as possible.
12. Stained ice trays	Poor cleaning procedures	Use soap and warm water to wash trays. Rinse them thoroughly. Do not use metal sponges, steel wool, or course cleaning powders.

5.3.1 Single Door Fresh Food Refrigerator

A single door fresh food refrigerator consists of an evaporator placed either across the top or in one of the upper corners of the cabinet (*Figure 12-37*). The condenser is on the back of the cabinet or in the bottom of the cabinet below the hermetic compressor. During operation, the cold air from the evaporator flows by natural circulation through the refrigerated space. The shelves inside the cabinet are constructed so air can circulate freely past the ends and sides, eliminating the need for a fan.

This type of refrigerator has a manual defrost, which requires the refrigerator to be turned off periodically (usually overnight), to allow the frost buildup on the evaporator to melt. Both the outside and inside finish is usually baked-on enamel. Porcelain enamel is found on steel cabinet liners. The interior of the unit contains the shelves, lights, thermostats, and temperature controls.



Figure 12-37 – Single-door fresh food refrigerator.

5.3.2 Two-Door Refrigerator-Freezer Combination

The two-door refrigerator-freezer combination is the most popular type of refrigerator (*Figure 12-38*). It is similar to the fresh food refrigerators in construction and the location of components except it sometimes has an evaporator for both the freezer compartment and the refrigerator

compartment. Also, if it is a frost-free unit, the evaporators are on the outside of the cabinet. Because of the two separate compartments (refrigerator-freezer) and the larger capacity, these types of refrigerators use forced air (fans) to circulate the air through the inside of both compartments. In addition to the automatic icemaker in the freezer compartment, it has an option for a cold water dispenser, a cube or crushed ice dispenser, and a liquid dispenser built into the door. The two-door refrigerator also has one of the following three types of evaporator defrost systems: manual defrost, automatic defrost, or frost-free.



Figure 12-38 - Two-door refrigerator-freezer combination.

There are two types of automatic defrosting: the hot

gas system or the electric heater system. The hot gas system has solenoid valves, and uses the heated vapor from the compressor discharge line and the condenser to defrost the evaporator. The other system uses electric heaters to melt the ice on the evaporator surface.

A frost-free refrigerator-freezer has the evaporator located outside the refrigerated compartment (*Figure 12-39*). On the running part of the cycle, air is drawn over the evaporator and is forced into the freezer and refrigerator compartments by a fan. On the off part of the cycle, the evaporators automatically defrost.

Refrigerator-freezer cabinets are made of pressed steel with a vinyl or plastic lining on the interior wall surfaces and a lacquer exterior finish. Most domestic refrigerators have urethane foam or fiber glass insulation in the cabinet walls. The side-by-side refrigerator-freezer arrangement has a number of features not found in other refrigerators.

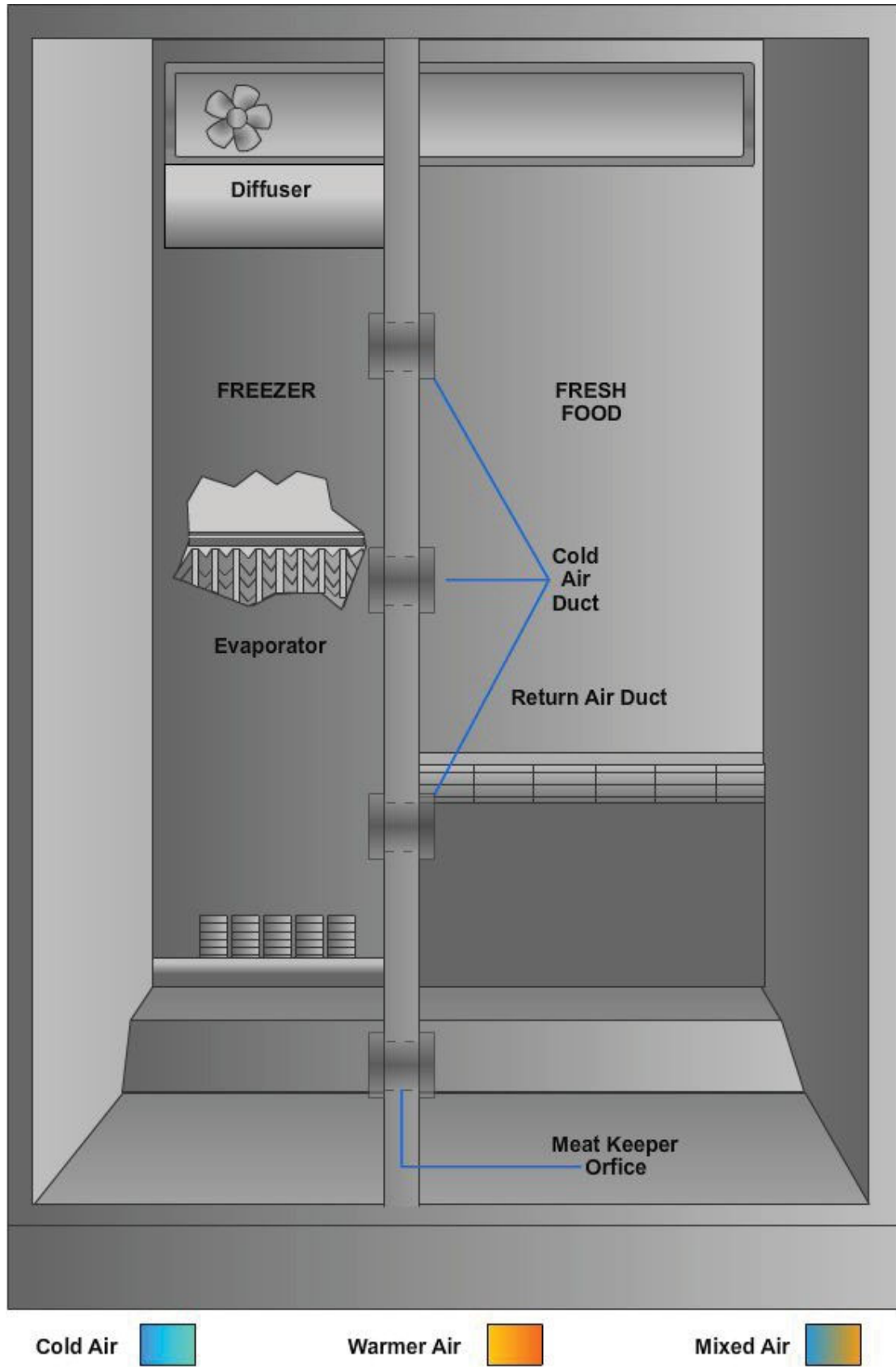

Figure 12-39 – Frost-free refrigerator airflow diagram.

5.4.0 Water Coolers and Ice Machines

Water coolers provide drinking water at a temperature under 50°F. Two types of water coolers are instantaneous and storage. The instantaneous type only cools water when it is being drawn; the storage type maintains a reservoir of cooled water. One instantaneous method places coils in a flooded evaporator through which the water flows. A second instantaneous method uses double coils with water flowing through the inner coil and refrigerant flowing in the space between the inner coil and the outer coil. A third instantaneous method is to coil the tubing in a water storage tank, allowing refrigerant to flow through it (Figure 12-40).

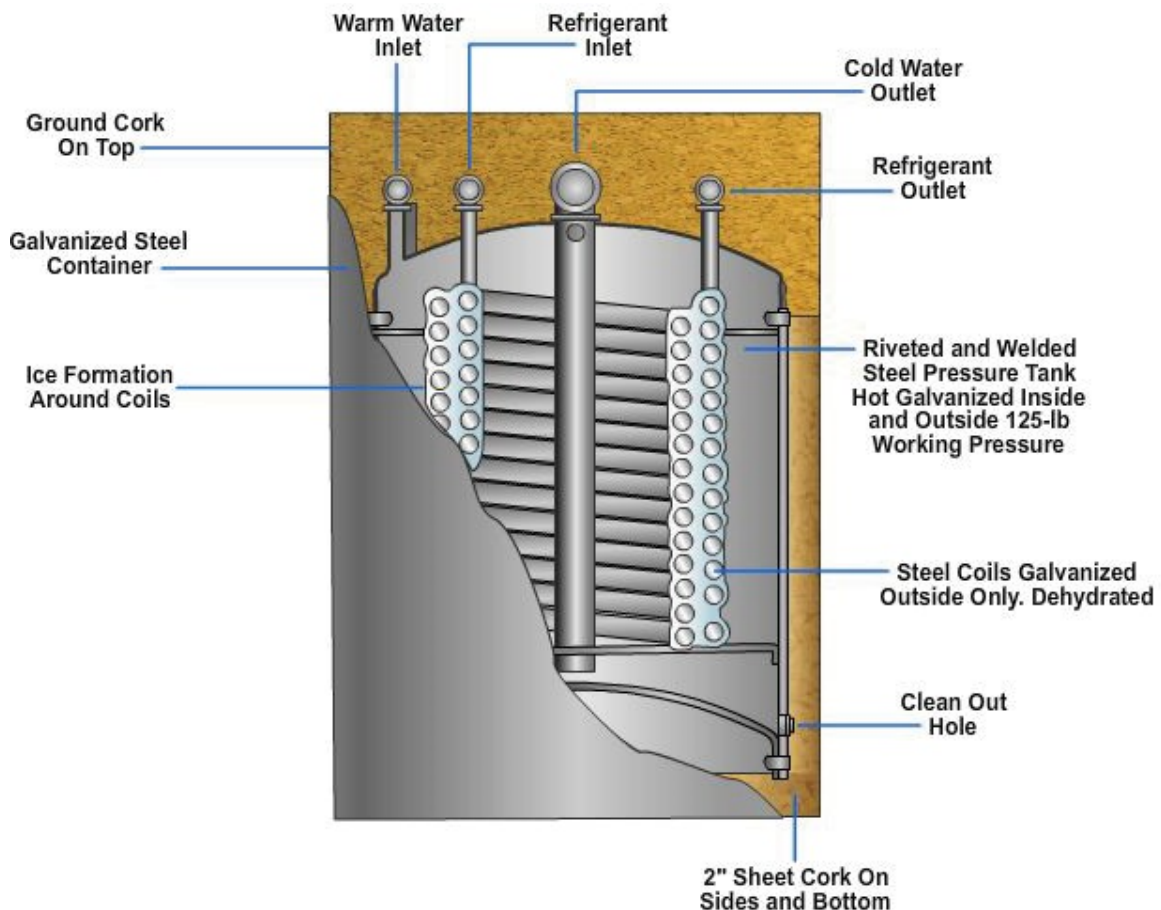

Figure 12-40 – Storage type of water cooler.

The two basic designs for water coolers are wall mounted or floor mounted. Both types are the same in construction and operation; the only difference is in the method of installation. Water cooler cabinets have a sheet metal housing attached to a steel framework. The condenser and hermetic compressor are located in the housing base, and the evaporator is located in the cabinet depending on its type of evaporator, but normally under the drain basin. Most water coolers use a heat exchanger or precooling, which pre-cools the fresh water line to the evaporator, reducing cooling requirements for the evaporator. A thermostat, which is manually set and adjusted, is located in the cooler housing close to the evaporator.

Automatic ice machines are often used in galleys, barracks, gymnasiums, and other public areas. Ice machines are self-contained, automatic machines, ranging from a small unit producing 50 pounds of ice per day (*Figure 12-41*) to a commercial unit producing 2,400 pounds of ice

per day (*Figure 12-42*). The primary difference in the design of these machines is the evaporator. They automatically control water feed to the evaporator, freeze the water in an ice cube mold, heat the mold and empty the ice into a storage bin, and shut down when the storage bin is full. Floats and solenoids control water flow, and switches operate the storing action when ice is made.

Depending on the type of unit, electrical heating elements, hot water, hot gas defrosting, or mechanical devices remove the ice from the freezing surfaces.

Figure 12-43 and *Figure 12-44* show the freezing and defrost

cycle of a typical ice cube machine.



Figure 12-41 – Small automatic ice machine.



Figure 12-42 – Commercial automatic ice machine.

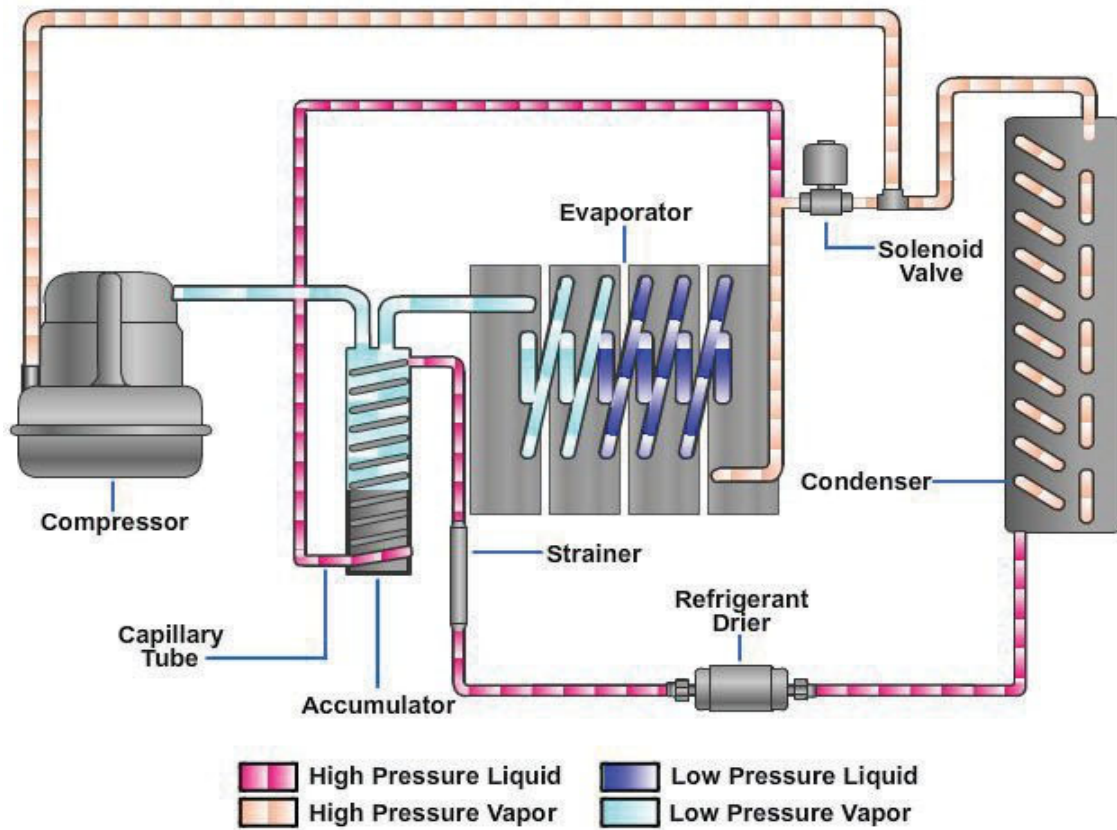

Figure 12-43 – Freeze cycle of an ice cube machine.

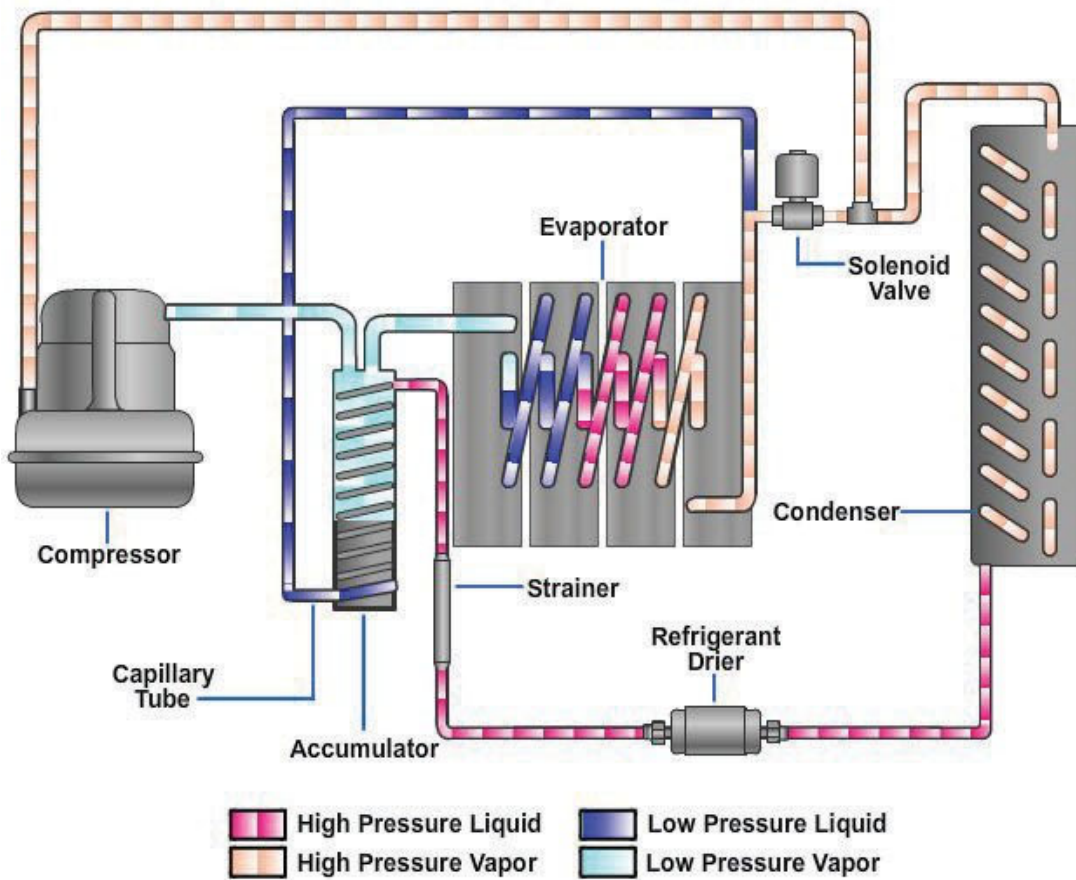

Figure 12-44 – Defrost cycle of an ice cube machine.

Test your Knowledge (Select the Correct Response)

8. What type of refrigerator has a manual defrost that requires the unit to be turned off to melt the frost buildup on the evaporator?
- A. Two-door refrigerator-freezer
 - B. Reach-in
 - C. Single-door fresh food
 - D. Walk-in
9. **(True or False)** The two basic designs for water coolers, wall mounted and floor mounted, are very different when it comes to construction and operation.
- A. True
 - B. False

6.0.0 INSTALLATION of REFRIGERATION EQUIPMENT

As a UT, you can be tasked to install refrigeration systems. Therefore, it is important for you to understand the basic requirements for installing the various types of refrigeration equipment.

When installing a refrigeration or air-conditioning plant, you must not allow dirt, scale, sand, or moisture to enter any part of the refrigerant system. Since air contains moisture, its entrance into the circuit should be controlled as much as possible during installation. Most maintenance problems come from careless erection and installation. All openings to the refrigerant circuit-piping, controls, compressor, condensers, and so on-must be adequately sealed when you are working on them.

Most refrigerants are powerful solvents that readily dissolve foreign matter and moisture that may have entered the system during installation. This material is soon carried to the operating valves and the compressor. It becomes a distinct menace to bearings, pistons, cylinder walls, valves, and the lubricating oil. Scoring of moving parts frequently occurs when the equipment is first operated, starting with minor scratches that increase until the operation of the compressor is seriously affected.

Under existing specifications, copper tubing and copper piping needed for installation should be cleaned, deoxidized, and sealed. If you are not sure about the cleanliness of the tubing or piping you are going to use, blow out each length of pipe with a strong blast of dry air. Next, use a copper wire with a cloth swab attached to it to pull back and forth in the tube until it is clean and shiny. Then seal the ends of the tubes to keep them clean until they are connected to the rest of the system.

6.1.0 Effects of Moisture

As little as 15 to 20 parts of moisture per million parts of refrigerant can cause severe corrosion in a system. When the refrigerant comes in contact with water, hydrochloric acid is formed causing corrosion. Corrosion products are formed when a chemical reaction takes place between the acid and the iron and copper in the system.

Combining a strong acid with high discharge and compressor temperature can cause decomposition of the system's lubricating oil, and produce a sludge containing breakdown products. A serious casualty can occur when either the corrosion or the oil breakdown products plug the valves, strainers, and dryers.

NOTE

The formation of ice from a minute quantity of moisture in expansion valves and capillary tubes can occur when operating below 32°F.

6.2.0 Location of Equipment

You should always leave adequate space around major portions of equipment for servicing purposes; otherwise, the equipment must be moved after installation to have access to serviceable parts (*Figures 12-45 and 12-46*). Enough overhead clearance is required for compressors when removing the head, discharge valve plate, and pistons. There should also be enough side clearance if it becomes necessary to remove the flywheel and crankshaft. Water-cooled condensers require a free area equal to the length of the condenser at one end to provide room for cleaning tubes, installing new tubes, or removing the condenser tube assembly. Space is needed for servicing valves and accessory equipment. In most instances, service openings and inspection panels on unit equipment require at least 18 inches of clearance when removing the panels.

Place air-cooled condensing units in a location that permits unrestricted flow of air for condensing, whether the condenser is part of the unit or separate. Overloading of the motor and loss of capacity can occur when there is inadequate ventilation around air-cooled condensers.

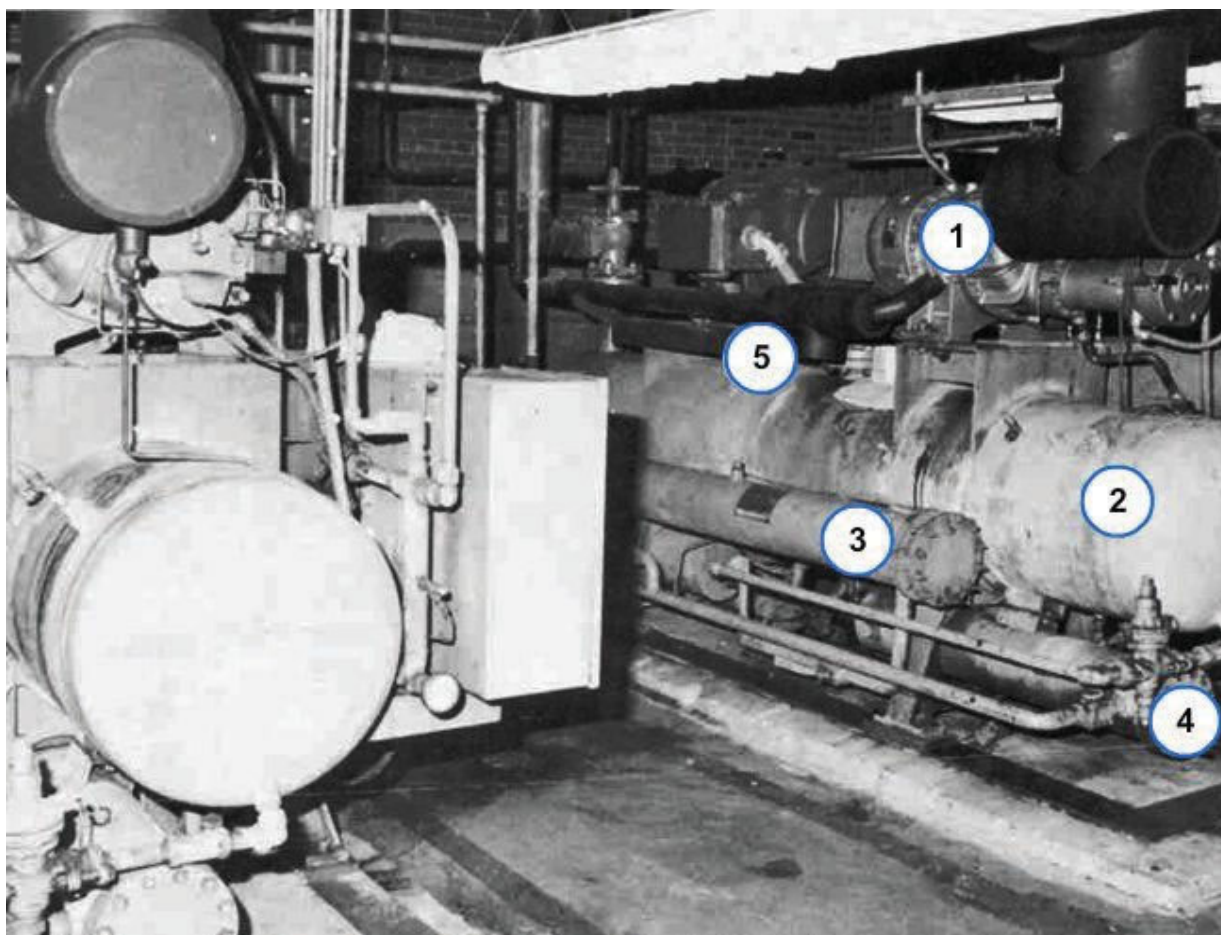

Figure 12-45 – Low-temperature screw or helix compressor system.
(1) Compressor; (2) Oil separator and reservoir; (3) Oil cooler;
(4) Oil filters; (5) Hot gas discharge line.

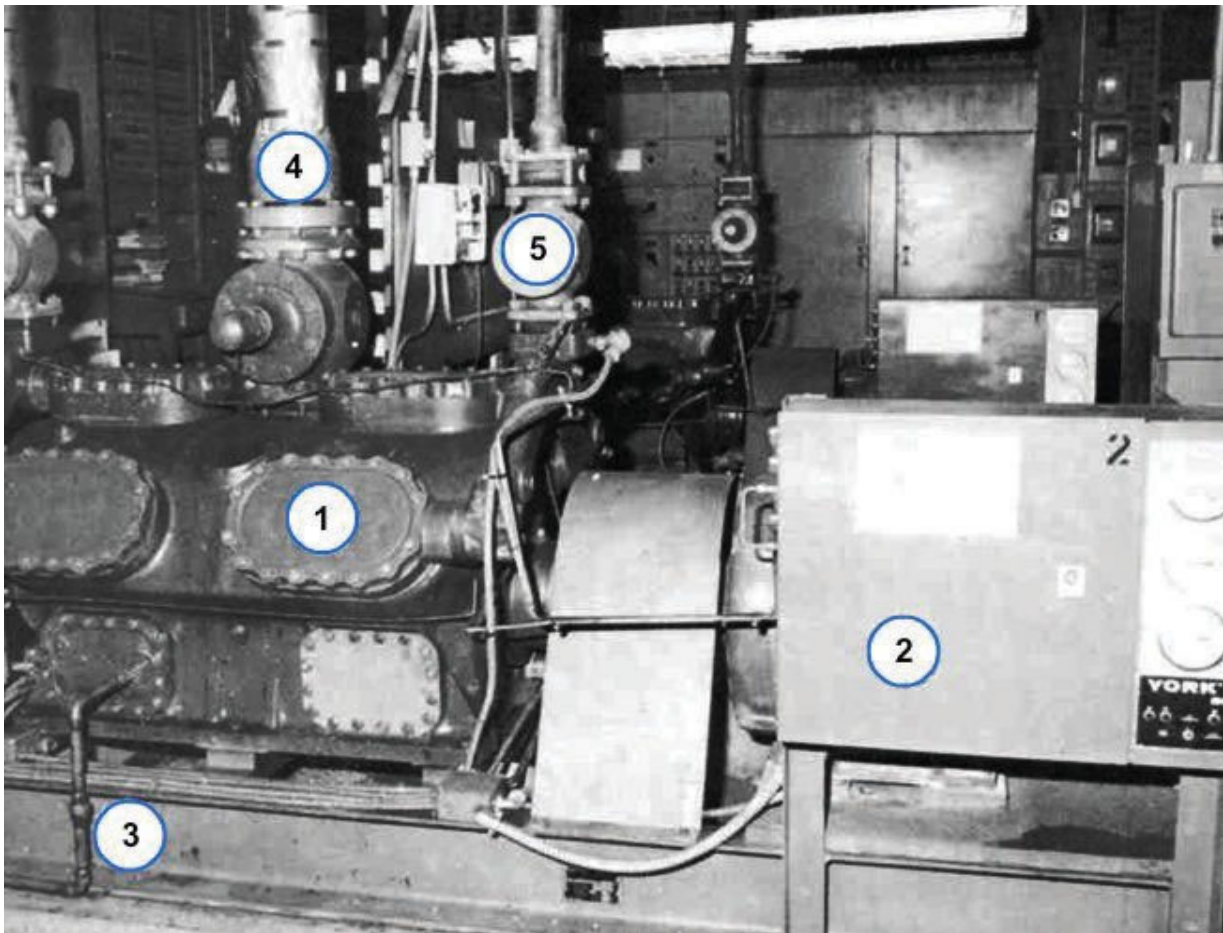

Figure 12-46 — Twelve-cylinder semi-hermetic reciprocating direct drive compressor system. (1) Compressor; (2) Control panel; (3) Oil return from reservoir; (4) Section line; (5) Hot gas discharge line.

6.3.0 Refrigerant Piping

If you are assigned to install refrigerant lines, you must follow certain general precautions. When the receiver is above the cooling coil, the liquid line should be turned up before going down to the evaporator. This inverted loop prevents siphoning of the liquid from the receiver over into the cooling coil through an open or leaking expansion valve during compressor shutdown periods. If siphoning starts, the liquid refrigerant flashes into a gas at the top of the loop, breaking the continuity of the liquid volume and stopping the siphoning action. Where the cooling coils and compressors are on the same level, both the suction and liquid lines should be run to the overhead and then down to the condensing unit, pitching the suction line toward the compressor to ease oil return. On close-coupled installations, running both lines up to the overhead helps to eliminate vibration strains as well as provide the necessary trap at the cooling coil.

Make sure you use care when preparing pipes and fittings. This is particularly important when cutting copper tubing or pipe to prevent the small filings or cuttings from entering the pipe. You should completely remove the small particles of copper to prevent them from passing through the suction strainer. Cut the tube square, and remove all burrs and dents to prevent internal restrictions and to permit proper fit with the companion fittings. If you are going to do the cutting with a hacksaw, use a fine-toothed blade, preferably 32 teeth per inch. Whenever possible, you should avoid using a hacksaw.

When making silver-solder joints, brighten up the ends of the tubing or pipe with a wire

brush or crocus cloth to make a good bond. When you are doing this cleaning, you should not use sandpaper, emery cloth, or steel wool because this type material can cause problems if it enters the system.

Acid should never be used for soldering, nor should flux be used if its residue forms an acid. If you do use flux, use it sparingly so no residue will enter inside the system and eventually be washed back to the compressor crankcase. If tubing and fittings are improperly fitted because of distortion, too much flux, solder, and brazing material may enter the system.

The temperature required to solder or braze pipe joints causes oxidation within the tubing. Once the system is in operation, the refrigerant flow eventually removes the oxidation. When the oxide breaks up into a fine powder, it contaminates the lubricant in the compressor and plugs strainers and driers. To eliminate the oxide breakup, you need to provide a neutral atmosphere within the tube being soldered or brazed. Use gas-bleed nitrogen through the tubing during soldering or brazing, and for a sufficient time after the bond is made, which lowers the heat of the copper below the temperature of oxidation.

All joints should be silver-soldered and kept to a minimum to reduce leaks. Make sure you use special copper tube fittings which are designed for refrigeration service. These types of fittings are manufactured with close tolerances to assure tight capillary joints during the brazing process.

SAE flare joints are generally not desired, but when necessary, you should take care when making the joint. The flare must be of uniform thickness and present a smooth, accurate surface, free from tool marks, splits, or scratches. The tubing must be cut square, provided with a full flare, and any burrs and saw filings removed. The flare seat of the fitting connector must be free from dents or scratches. The flare can best be made with a special swivel head flaring tool, which remains stationary and does not



Figure 12-47 – Swivel-head flaring tool.

tear or scar the face of the flare in the tubing (*Figure 12-47*).

When you are making up the flare or securing it to the fitting, do not use oil on the face of the flare. If oil is placed on the face, it will eventually be dissolved by the system's refrigerant, resulting in a leak through the displacement of the oil. Always use two wrenches when you are tightening the flare joint. Use one wrench to turn the nut while the other holds the connecting piece to avoid strain on the connection, which can cause a leak.

Where pipe or tubing has to be bent, bends should be made with special tools designed for this type of work (*Figure 12-48*). Do not use rosin, sand, or any other filler inside the tubing to make a bend. Threaded joints should be coated with a special refrigerant pipe dope. In an emergency, use a thread compound for making up a joint; remember if you using refrigerants that are hydrocarbons, they will dissolve any compound containing oil. Also, you should not use a compound containing an acid or one whose residual substance forms an acid. The use of a thick paste made of fresh lethargy and glycerin makes a satisfactory joint compound; however, the joint should be thoroughly cleaned with a solvent to eliminate oil or grease. Thread compounds should be applied to the male part of the thread after it has entered the female coupling one and one-half to two threads to prevent any excess compound from entering the system.



Figure 12-48 – Pipe or tube bending tool.

When securing, anchoring, or hanging the suction and liquid lines, be sure and allow enough flexibility between the compressor and the first set of hangers or points where the lines are secured to permit some degree of freedom. This flexibility relieves strain in the joints of these lines at the compressor due to compressor vibration.

6.4.0 Multiple Compressors

Parallel operation of two or more reciprocating compressors should be avoided unless there are strong and valid reasons for not using a single compressor. If you have a situation where you have to use two compressors, it is essential that you take extreme care when sizing and arranging the piping system.

An acceptable arrangement of two compressors and two condensers is shown in *Figure 12-49*. An equalizer line connects the crankcase at the oil level of each machine.

Therefore, the oil in both machines will be at a common level. If machines of different sizes are used, the height of the bases beneath the machines must be adjusted so the normal oil level of both machines is at the same elevation; otherwise, the oil accumulates in the lower machine.

This arrangement is called a single-pipe crankcase equalizer. It can be used only on those machines with a single equalizer tapping entering the crankcase in such a position that the bottom of the tapping just touches the normal oil level.

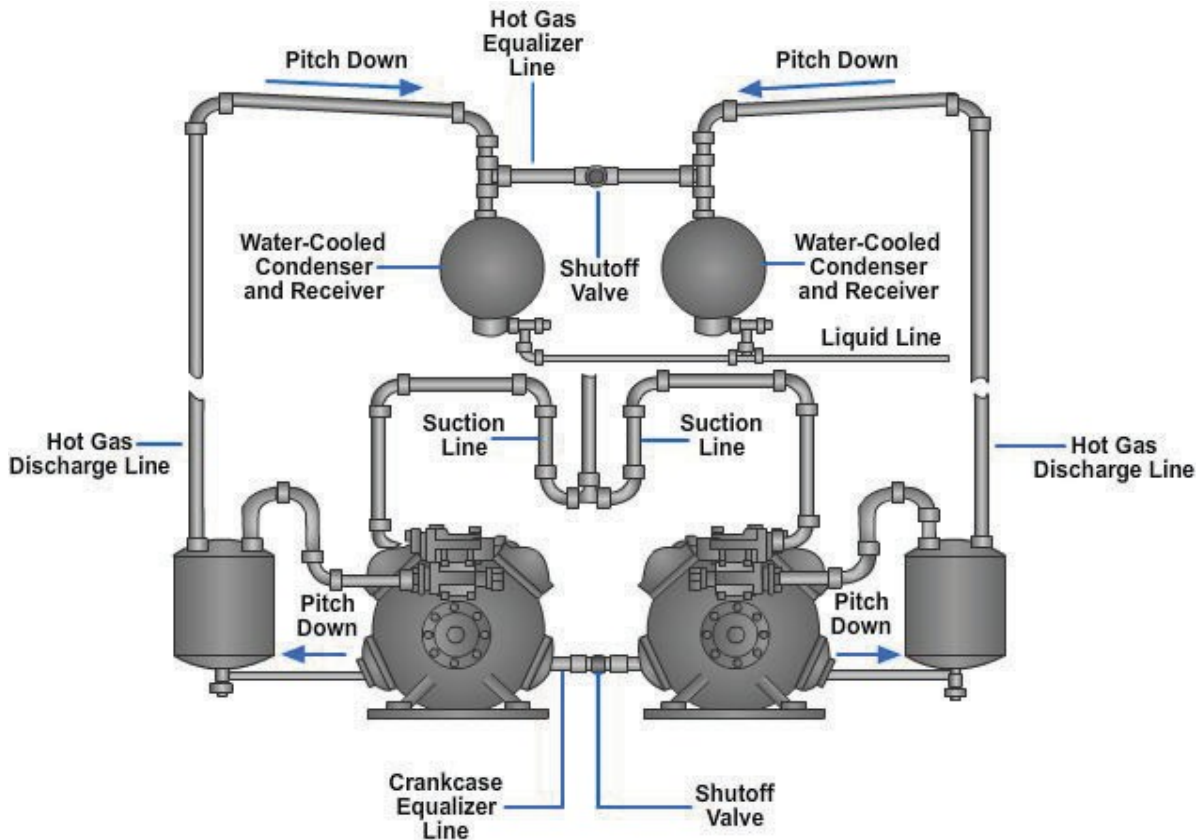

Figure 12-49 – Parallel compressors with separate condensers.

Another method of piping to maintain proper oil level in two or more compressors uses two equalizer lines between the crankcase—one above the normal oil level and one below. The double equalizer system must be used on compressors having two equalizer tapplings. Make sure you never use a single equalizer line on machines having two equalizer tapplings.

The lower oil equalizer line must not rise above the oil level in the crankcase and should be as level as possible. This is important since the oil builds up in one crankcase if the line rises. The upper equalizer line is a gas line intended to prevent any difference in crankcase pressure that would influence the gravity flow of oil in the lower equalizer line or the level of oil in the crankcase. This upper line must not dip, and care should be taken to eliminate pockets in which oil could accumulate to block the flow of gas. Valves in the crankcase equalizer lines are installed with the stems horizontal, so no false oil levels are created by oil rising over the valve seat and minimizing flow resistance.

When making up the equalizer line, you should not skimp on the piping. Also, oversize piping is preferred to undersize piping. A good rule to follow is to use oil equalizer lines equal to the full size of the tapping in the compressor.

The discharge lines from the compressors are also equalized before they enter the condensers. This, in effect, causes the individual condensers to function as a single unit. This is the most critical point in the piping system. It is here that pressure drop is extremely important—a pressure drop of 0.5 psi being equal to a 1.0 foot head of liquid. Excessive pressure drop in the equalizer line may rob one condenser of all liquid by forcing it into the other condenser. One of the results may be the pumping of large quantities of hot refrigerant vapor into the liquid lines from the condenser of the

operating compressor. This could reduce the capacity of the system materially. For this reason, the equalizer line should be just as short and level as possible. A long equalizer line introduces an unequal pressure in condensers if one of the compressors is not operating. The refrigerant then accumulates in the condenser of the non-operating compressor. The equalizer line should also be generously sized and should be equal to or larger than the discharge line of the largest compressor being used.

If the condensers are more than 10 feet above the compressor, U-traps or oil separators should be installed in the horizontal discharge line where it comes from each compressor.

The traps or separators prevent the oil from draining back to the compressor head on shutdown. Should a single compressor or multiple compressors with capacity modulation be used in an instance of this kind, another solution may be dictated. When a compressor unloads, less refrigerant gas is pumped through the system. The velocity of flow in the refrigerant lines drops off as the flow decreases. It is necessary to maintain gas velocities above some minimum value to keep the entrained oil moving with the refrigerant. The problem becomes particularly acute in refrigerant gas lines when the flow is upward. It does not matter whether the line is on the suction or discharge side of the compressor; the velocity must not be allowed to drop too low under low refrigerant flow conditions. Knowing the minimum velocity, 1,000 feet per minute (fpm) for oil entrainment up a vertical riser and the minimum compressor capacity, the designer of the piping can overcome this problem using a double riser.

The smaller line in the double riser is designed for minimum velocity, at the minimum step, of compressor capacity. The larger line is sized to assure that the velocity in the two lines at full load is approximately the same as in the horizontal flow lines. A trap of minimum dimensions is formed at the bottom of the double-riser assembly, which collects oil at minimum load. Trapped oil then seals off the larger line so the entire flow is through the smaller line.

If an oil separator is used at the bottom of a discharge gas riser, the need for a double riser is eliminated. The oil separator will do as its name implies-separate the major part of the oil from the gas flowing to it and return the oil to the compressor crankcase. Since no oil separator is 100 percent effective, the use of an oil separator in the discharge line does not eliminate the need for double risers in the suction lines of the same system if there are vertical risers in the suction lines. When multiple compressors with individual condensers are used, the liquid lines from the condenser should join the common liquid line at a level well below the bottoms of the condensers. The low liquid line prevents gas from an "empty" condenser from entering the line because of the seal formed by the liquid from other condensers.

NOTE

A common water-regulating valve should control the condenser water supply for a multiple system using individual condensers so each condenser receives a proportional amount of the condenser water.

Frequently, when multiple compressors are installed, only one condenser is provided. Such installations are satisfactory only as long as all of the compressors are operating at the same suction pressure. However, several compressors may occasionally be installed which operate at different suction pressures-the pressures corresponding, of course, to the various temperatures needed for the different cooling loads. When this is the case, a separate condenser must be installed for each compressor or group of compressors operating at the same suction pressure. Each compressor or group of compressors operating at one suction pressure must have a complete piping system

with an evaporator and condenser separate from the remaining compressors operating at other suction pressures. Separate systems are required because the crankcase of compressors operating at different suction pressures cannot be interconnected. There is no way of equalizing the oil return to such compressors.

The suction connection to a multiple compressor system should be made through a suction manifold, as shown in *Figure 12-49*. The suction manifold should be as short as possible and should be taken off in such a manner that any oil accumulating in the header returns equally to each machine. Evaporative condensers can be constructed with two or more condensers built into one spray housing. This is accomplished quite simply by providing a separate condensing coil for each compressor, or a group of compressors operating at the same suction pressure. All of the condensing coils are built into one spray housing; this provides two or more separate condensers in one condenser housing.

Test your Knowledge (Select the Correct Response)

10. What type of acid is formed when refrigerant is mixed with water?
 - A. Hydrofluoric
 - B. Sulfuric
 - C. Hydrochloric
 - D. Carbonic

11. U-traps or oil separators should be installed on multiple compressor systems when the condensers are how many feet above the compressor?
 - A. 10
 - B. 12
 - C. 13
 - D. 15

7.0.0 MAINTENANCE, SERVICE, and REPAIR of REFRIGERATION EQUIPMENT

As a UT, you must be able to maintain, service, and repair refrigeration equipment. When information here varies from that in the latest federal or military specifications, the specifications apply. You will find *Table 12-4* helpful in troubleshooting refrigeration system problems. It is not intended to be all encompassing. Manufacturers also provide instruction manuals to aid you in maintaining and servicing their equipment.

Table 12-4 – Troubleshooting checklist for refrigeration systems

TROUBLE	POSSIBLE CAUSE	CORRECTIVE MEASURE
High condensing pressure	Air or non-condensable gas in system.	Purge air from condenser.
	Inlet water warm.	Increase quantity of condensing water.
	Insufficient water flowing through condenser.	Increase quantity of water.
	Condenser tubes clogged or scaled.	Clean condenser water tubes.

Table 12-4 – Troubleshooting checklist for refrigeration systems (cont.)

TROUBLE	POSSIBLE CAUSE	CORRECTIVE MEASURE
	Too much liquid in receiver, condenser tubes submerged in liquid refrigerant.	Draw off liquid into service cylinder.
	Insufficient cooling of air-cooled condenser.	Check fan operation, cleanliness of condenser, and for adequate source of air flow.
Low condensing pressure.	Too much water flowing through condenser.	Reduce quantity of water.
	Water too cold.	Reduce quantity of water.
	Liquid refrigerant flooding back from evaporator.	Change expansion valve adjustment, examine fastening of thermal bulb.
	Leaky discharge valve.	Remove head, examine valves. Replace any found defective.
High suction pressure.	Overfeeding of expansion valve. Leaky suction valve.	Regulate expansion valve, check bulb attachment. Remove head, examine valve and replace if worn.
Low suction pressure.	Restricted liquid line and expansion valve or suction screens.	Pump down, remove, examine and clean screens.
	Insufficient refrigerant in system.	Check for refrigerant storage.
	Condenser tubes clogged or scaled.	Clean condenser water tubes.
	Too much oil circulating in system.	Check for too much oil in circulation. Remove oil.
	Improper adjustment of expansion valves.	Adjust valve to give more flow.
	Expansion valve power element dead or weak.	Replace expansion valve power element.
	Low refrigerant charge.	Locate and repair leaks. Charge refrigerant.
Compressor short cycles on low-pressure control.	Thermal expansion valve not feeding properly. 1. Dirty strainers 2. Moisture frozen in orifice or orifice plugged with dirt. 3. Power element dead or weak.	Adjust, repair, or replace thermal expansion valve. 1. Clean strainers. 2. Remove moisture or dirt (Use system dehydrator). 3. Replace power element.
	Water flow through evaporators restricted or stopped. Evaporator coils plugged, dirty, or clogged with frost.	Remove restriction. Check water flow. Clean coils or tubes.

Table 12-4 – Troubleshooting checklist for refrigeration systems (cont.)

TROUBLE	POSSIBLE CAUSE	CORRECTIVE MEASURE
Compressor short cycles on low-pressure control (cont.).	Defective low-pressure control switch.	Repair or replace low-pressure control switch.
Compressor runs continuously.	Shortage of refrigerant.	Repair leak and recharge system.
	Leaking discharge valves.	Replace discharge valves.
Compressor short cycles on high-pressure control switch.	Insufficient water flowing through condenser, clogged condenser.	Determine if water has been turned off. Check for scaled or fouled condenser.
	Defective high-pressure control switch.	Repair or replace high-pressure control switch.
Compressor will not run.	Seized compressor.	Repair or replace compressor.
	<p>Cut-in point of low-pressure control switch too high.</p> <p>High-pressure control switch does not cut in.</p> <ol style="list-style-type: none"> 1. Defective switch. 2. Electric power cut-off. 3. Service or disconnect switch open. 4. Fuses blown. 5. Overload relays tripped. 6. Low voltage. 7. Electrical motor in trouble. 8. Trouble in starting switch or control circuit. 9. Compressor motor stopped by oil-pressure differential switch. 	<p>Set L.P. control switch to cut in at correct pressure.</p> <p>Check discharge pressure and reset H.P. control switch.</p> <ol style="list-style-type: none"> 1. Repair or replace switch. 2. Check power supply. 3. Close switches. 4. Test fuses and renew if necessary. 5. Reset relays and find cause of overload. 6. Check voltage (should be within 10 percent of nameplate rating). 7. Repair or replace motor. 8. Close switch manually to test power supply. If OK check control circuit including temperature and pressure controls. 9. Check oil levels in crankcase. Check oil pressure.
Sudden loss of oil from crankcase.	Liquid refrigerant slugging back to compressor crankcase.	Adjust or replace expansion valve.
Capacity reduction system fails.	Hand-operating stem of capacity control valve not turned to automatic position.	Set hand-operating stem to automatic position.

Table 12-4 – Troubleshooting checklist for refrigeration systems (cont.)

TROUBLE	POSSIBLE CAUSE	CORRECTIVE MEASURE
Compressor continues to operate at full or partial load.	Pressure-regulating valve not opening.	Adjust or repair pressure-regulating valve.
Capacity reduction system fails to load cylinders.	Broken or leaking oil tube between pump and power element.	Repair leak.
Compressor continues to operate unloaded.	Pressure-regulating valve not closing.	Adjust or repair pressure-regulating valve.

7.1.0 Servicing Equipment

Repair and service work on a refrigeration system consists mainly of containing refrigerant and measuring pressures accurately. One piece of equipment is the refrigerant gauge manifold set (*Figure 12-50*). It consists of a 0-500 psig gauge for measuring pressure at the compressor high side, a compound gauge (0-250 psig and 0 to -30 inches of mercury) to measure the low or suction side, and valves to control admission of the refrigerant to the refrigeration system. It also has the connections and lines required to connect the test set to the system.

Depending on test and service requirements, the gauge set can be connected to the low side, the high side, a source of vacuum, or a refrigerant cylinder. A swiveling hanger allows the test set to be hung easily.

Another important piece of equipment is the portable vacuum pump. The type listed in the Seabee Table of Allowance is a sealed unit consisting of a single-piston vacuum pump driven by an electric motor. A vacuum pump is the same as a compressor, except the valves are arranged so the suction valve is opened only when the



Figure 12-50 – Refrigerant gauge manifold set.

suction, developed by the downward stroke of the piston, is greater than the vacuum already in the line. This vacuum pump can develop a vacuum close to -30 inches of mercury, which can be read on the gauge mounted on the unit (*Figure 12-51*). The pump reduces the pressure in a refrigeration system to below atmospheric pressure.

The Navy uses hermetic refrigeration systems produced by various manufacturers, which can vary the connectors and tubing size being used. The Table of Allowance provides for a refrigeration service kit that contains several adapters, wrenches, and other materials to help connect different makes of systems to the refrigerant manifold gauge set and the vacuum pump lines. A table affixed to the lid of the storage container identifies the adapter you should use for a particular refrigeration unit.

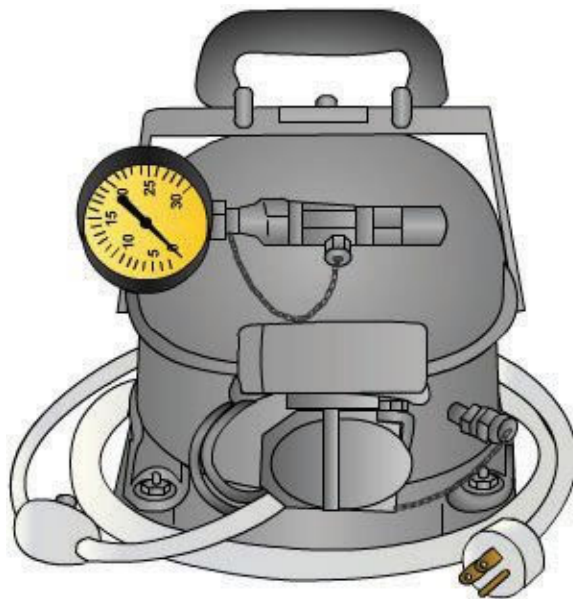

Figure 12-51 – Portable vacuum pump.

7.2.0 Transferring Refrigerants

Refrigerants are shipped in compressed gas cylinders as a

liquid under pressure. Liquids are usually removed from the shipping containers and transferred to a service cylinder (*Figure 12-52*). Before attempting transfer of refrigerants, you should precool the service cylinder until its pressure is lower than that of the storage cylinder. Precool the cylinder by placing it in ice water or a refrigerated tank. You must also weigh the service cylinder, including cap, and compare it with the **tare weight** stamped or tagged on the cylinder. The amount of refrigerant that may be placed in a cylinder is 85 percent of the tare weight (the weight of a full cylinder and its cap minus the weight of the empty cylinder and its cap).

To transfer refrigerants, you connect a flexible charging line on a 1/4-inch copper tube several feet long with a circular loop about 8 to 10 inches in diameter. Be sure to install a 1/4-inch refrigerant shutoff valve (*Figure 12-52*) in the charging line to the service cylinder. This valve should be inserted so no more than 3 inches of tubing is between the last fitting and the valve itself. This arrangement prevents the loss of refrigerant when the service drum is finally disconnected.

The entire line must be cleared of air by leaving the flare nut on the service cylinder loose and cracking the storage cylinder valve. This arrangement allows refrigerant to flow through the tubing, clearing it.

After clearing the line, tighten the flare nut and then open the valve on the service cylinder, the valve on the storage cylinder, and the 1/4-inch valve in the refrigerant line. When the weight of the service cylinder shows a sufficient amount of refrigerant is in the serviced cylinder, close all valves tightly, and disconnect the charging line at the service cylinder.

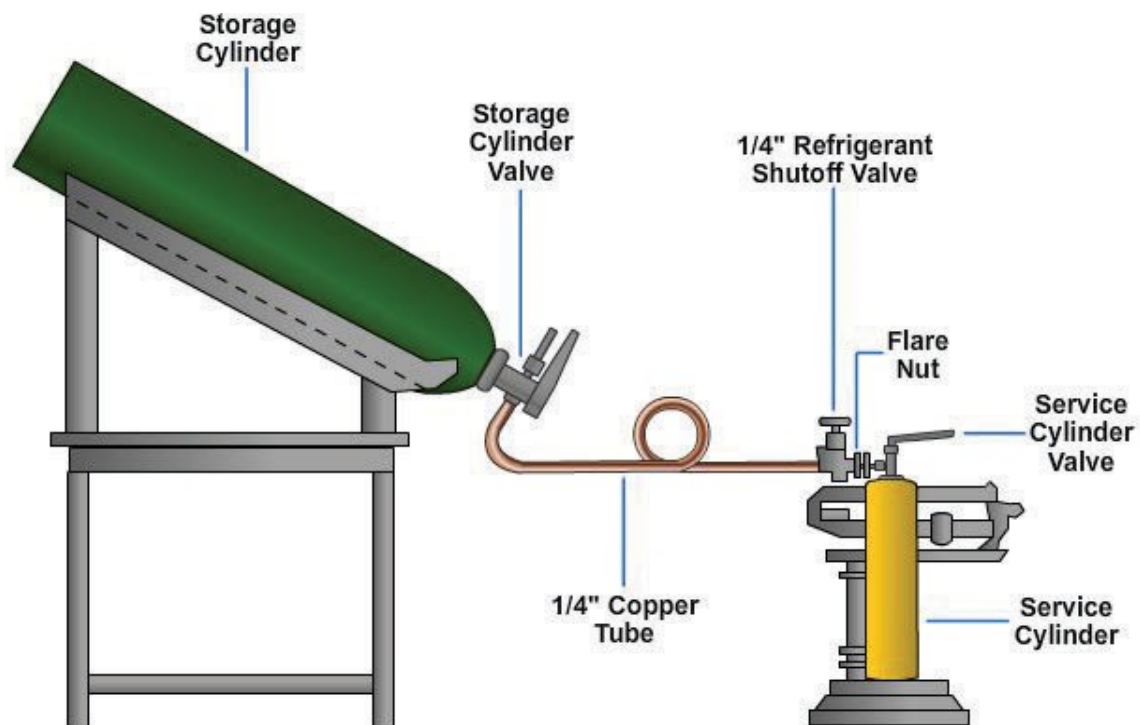

Figure 12-52 – Method of transferring refrigerants to service cylinders.

⚠ CAUTION ⚠

To warm refrigerant containers or cylinders for more rapid discharge, use care to prevent a temperature above 120°F because the fusible plugs in the cylinder and valve have a melting point of about 157°F.

7.3.0 Evacuating and Charging a System

One of your duties will be charging a system with refrigerant. If a system develops a leak, you must first repair the leak and then charge the system. Also, if a system component becomes faulty and has to be replaced, some refrigerant will be lost which requires you to recharge the system.

7.3.1 Evacuation

Before a system can be charged, all moisture and air must be eliminated from the components by drawing a vacuum on the system. To draw a vacuum on the system, proceed as follows:

1. Connect the portable vacuum pump to the vacuum fitting on the refrigerant manifold gauge set (*Figure 12-50*).
2. Connect the LO line (suction) to the suction service valve of the compressor, using appropriate connectors if required.
3. Turn the suction service valve to mid-position so vacuum draws from the compressor crankcase and suction line back through the evaporator, expansion

valve, condenser service valve, and liquid line. When the receiver service valve, condenser service valve, and discharge service valve are open, the pump draws back through the receiver and condenser to the compressor.

4. Attach one end of the 1/4-inch copper tube to the vacuum pump discharge outlet (*Figure 12-53*). Allow the vacuum pump to draw a vacuum of at least 25 inches. Submerge the other end of the copper tubing under 2 or 3 inches of clean compressor oil contained in a bottle.
5. Continue to operate the vacuum pump until there are no more bubbles of air and vapor in the oil, which indicates that a deep vacuum has been obtained.
6. Maintain the deep vacuum operation for at least 5 minutes, and then stop the vacuum pump. When vacuum pump discharge valves leak, it can cause oil to be sucked up into the copper discharge tube. It is important to keep the vacuum pump off for at least 15 minutes which allows air to enter the system through any leaks. Next, start the vacuum pump. Remember, a leaky system causes bubbling of the oil in the bottle.
7. Examine and tighten any suspected joints in the line, including the line to the vacuum pump. Repeat the test.

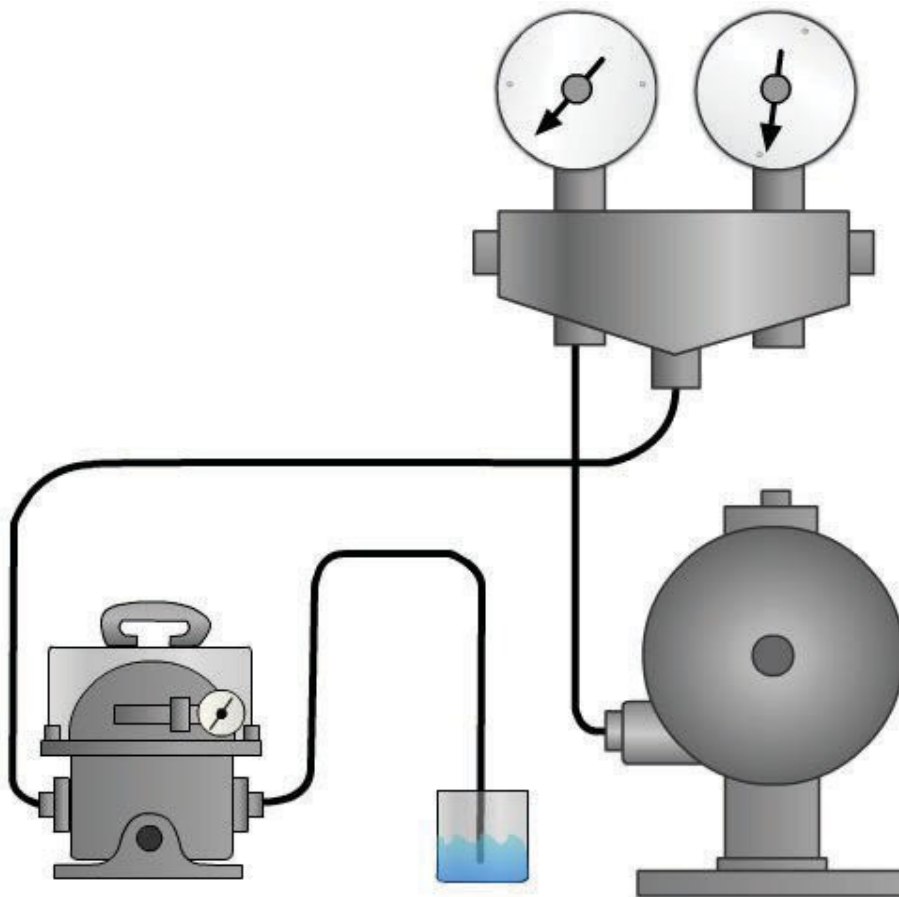

Figure 12-53 – Connections for drawing a vacuum.

7.3.2 Charging

In most small refrigerating systems, low-side charging is generally recommended for adding refrigerant after repairs have been made, and the system has been cleaned and tested for leaks (*Figure 12-54*).

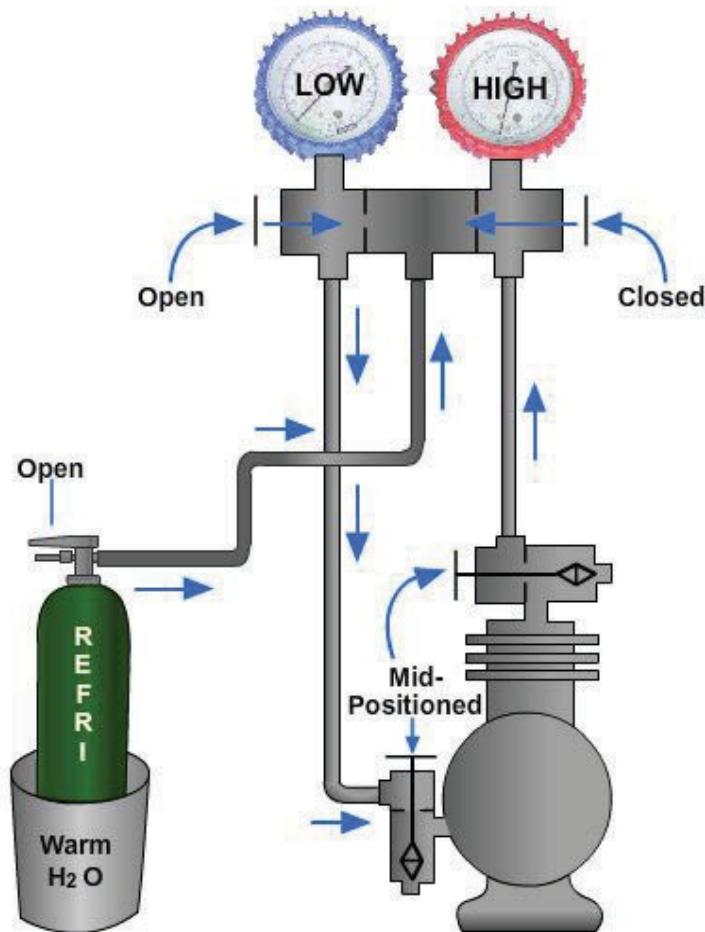

Figure 12-54 – Connections for low-side charging.

The steps for low-side charging a refrigeration system are as follows:

1. Connect a line from a refrigerant cylinder to the bottom center connection on the refrigerant gauge manifold set. Be certain the refrigerant cylinder is in a vertical position, so only refrigerant in the form of gas, not liquid, can enter the system. Leave the connection loose and crack the valve on the cylinder. This fills the line with gas and clears the air from the line. After clearing, tighten the connection.
2. Connect a line from the LOW (LO) valve (suction) on the gauge manifold to the suction service valve of the compressor.
3. Start the compressor.
4. Open the valve on the cylinder and the LOW (LO) valve (suction) on the gauge manifold set.
5. Open the suction service valve on the compressor to permit the gas to enter the compressor where it will be compressed and fed to the high side. Add the refrigerant slowly and check the liquid level indicator regularly until the system is fully charged. It is easy to check the receiver refrigerant level in some makes of condensing units because the receiver has minimum and maximum liquid level

indicator valves which show the height of the liquid level when opened. If a liquid line sight glass is used, the proper charge may be determined when there is no bubbling of refrigerant as it passes by the glass. The sight glass will appear empty.

Remember, liquid is not compressible, so be certain the refrigerant cylinder is in the vertical position at all times; otherwise, the liquid refrigerant will enter the compressor and damage the piston or other parts of the compressor.

7.4.0 Refrigerant Leaks

The best time for you to test the system joints and connections is when there is enough pressure to increase the rate at which the refrigerant seeps from the leaking joint. There is usually enough pressure in the high-pressure side of the system that is, in the condenser, receiver, and liquid line, including dehydrators, strainers, line valves, and solenoid valves. This is not necessarily true of the low-pressure side of the system, especially if it is a low-pressure installation for frozen foods and ice cream, where pressures may run only slightly above zero on the gauge. When there is little pressure, increase the pressure in the low-pressure side of the system by bypassing the discharging pressure from the condenser to the low-pressure side through the service gauge manifold. Regardless of the test method used, small leaks cannot be found unless the pressure inside the system is at least 40 to 50 psi.

7.4.1 Halide Leak Detector

The use of a halide leak detector is the most positive method of detecting leaks in a refrigerant system using halogen refrigerants (R-12, R-22, R-11, R-502, etc.) (*Figure 12-55*). Such a detector consists essentially of a torch burner, a copper reactor plate, and a rubber exploring hose.

Detectors use acetylene gas, alcohol, or propane as a fuel. A pump supplies the pressure for a detector that uses alcohol. If a pump-pressure type of alcohol-burning detector is used, be sure that the air pumped into the fuel tank is pure

An atmosphere suspected of containing a halogen vapor is drawn through the rubber exploring hose into the torch burner of the detector. Here the air passes over the copper reactor plate, which is heated to **incandescence**. If there is a minute trace of a halogen refrigerant present, the color of the torch flame changes from blue (neutral) to green as the halogen refrigerant contacts the reactor plate. The shade of green depends upon the amount of halogen refrigerant; a pale green color shows a small concentration and a darker green color, a heavier concentration. Too much of a halogen refrigerant causes the flame to burn with a vivid purple color. Extreme concentrations of a halogen refrigerant may extinguish the flame by crowding out the oxygen available from the air.

Normally, a halide leak detector is used for R-12 and R-22 systems. In testing for leaks always start at the highest point of the system and work towards the lowest point because halogen refrigerants are heavier than air.

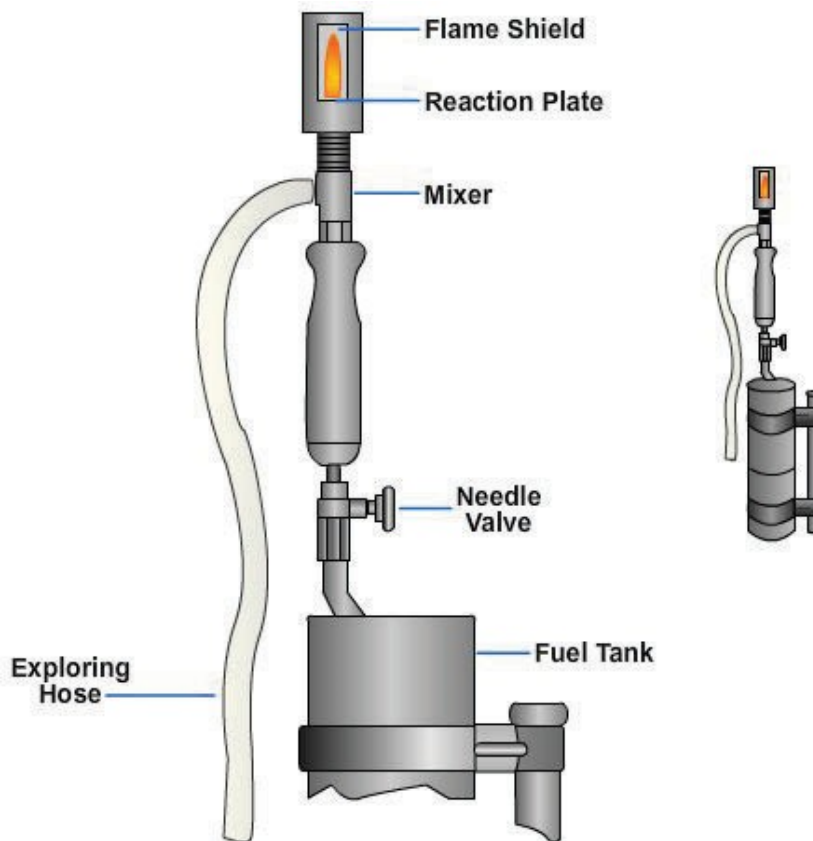

Figure 12-55 –Halide leak detector.

When using a leak detector, you will obtain the best results by following the precautions listed below:

1. Be sure the reactor plate is placed properly.
2. Adjust the flame so it does not extend beyond the end of the burner. (A small flame is more sensitive than a large flame. If it is hard to light the torch when it is adjusted to produce a small flame, block the end of the exploring hose until the fuel ignites; then gradually open the hose.)
3. Clean out the rubber exploring hose if the flame continues to have a white or yellow color. (A white or yellow flame is an indication that the exploring tube is partially blocked with dirt.)
4. Check to see that air is being drawn into the exploring tube; this check can be made from time to time by holding the end of the hose to your ear.
5. Hold the end of the exploring hose close to the joint being tested to prevent dilution of the sample by stray air currents.
6. Move the end of the exploring hose slowly and completely around each joint being tested. (Leak testing cannot be safely hurried. There is a definite time lag between the moment when air enters the exploring hose and the moment it reaches the reactor plate; permit enough time for the sample to reach the reactor plate.)

If a greenish flame is noted, repeat the test in the same area until the source of the refrigerant is located.

When testing for refrigerant leaks, you should always follow a definite procedure so none of the joints are missed. Even the smallest leaks are important. However slight a leak may seem, it eventually empties the system of its charge and causes faulty operation. In the long run, the extra time you spent in testing each joint will be justified. A refrigerant system should never be recharged until all leaks are found and repaired.

7.4.2 Electronic Leak Detector

The most sensitive leak detector of all is the electronic type (*Figure 12-56*). The principle of operation is based on the dielectric difference of gases. In operation, the gun is turned on and adjusted in a normal atmosphere. The leak-detecting probe is then passed around the surfaces

suspected of leaking. If there is a leak, no matter how tiny, the halogenated refrigerant is drawn into the probe. The leak gun then gives out a piercing sound, or a light flashes, or both, because the new gas changes the resistance in the circuit.

When using an electronic leak detector, minimize drafts by shutting off fans or other devices that cause air movement. Always position the sniffer below the suspected leak. Refrigerant drifts downward because it is heavier than air. Always remove the plastic tip and clean it before each use. Avoid clogging the tip with dirt and/or lint. After cleaning the tip move it slowly around the suspected leak.



Figure 12-56 – Electronic leak detector.

7.4.3 Soap and Water Test

Leakage of refrigerant with a pressure higher than atmospheric pressure may be tested using soap and water. Make a soap and water solution by mixing a lot of soap with water to a thick consistency. Let it stand until the bubbles have disappeared, and then apply it to the suspected leaking joint with a soft brush. Wait for bubbles to appear under the clear, thick soap solution.

When you are looking for extremely small leaks, use a strong light to examine any places that are suspect. If necessary, use a mirror to view the rear side of joints or other connections suspected of leaking.

7.5.0 Recovery, Recycling, and Reclaiming Refrigerant

Laws governing the release of chlorofluorocarbon refrigerants (CFCs) into the atmosphere have resulted in the development of procedures to recover, recycle, and reuse these refrigerants. Many companies have developed equipment necessary to prevent the release of CFCs into the atmosphere. Refrigerant recovery management equipment can be divided into three categories—recovery, recycle, and reclaiming equipment.

7.5.1 Recovery

Removing refrigerant from a system in any condition and storing it in an external container is called "recovery." When repair of a system is needed, removal of system refrigerant is necessary. To accomplish this task, you are required to use the special recovery equipment, which ensures complete removal of system refrigerant. This is sometimes referred to as pumping-down the system.

Recovery is similar to evacuating a system with the vacuum pump and is accomplished by either the vapor recovery or liquid recovery method. In the vapor recovery method a hose is connected to the low-side access point (compressor suction valve) through a filter-drier to the transfer unit, compressor suction valve (*Figure 12-57*). A hose is then connected from the transfer unit, compressor discharge valve to an external storage cylinder. When the transfer unit is turned on, it withdraws vapor refrigerant from the system into the transfer unit compressor, which in turn condenses the refrigerant vapor to a liquid and discharges it into the external storage cylinder.

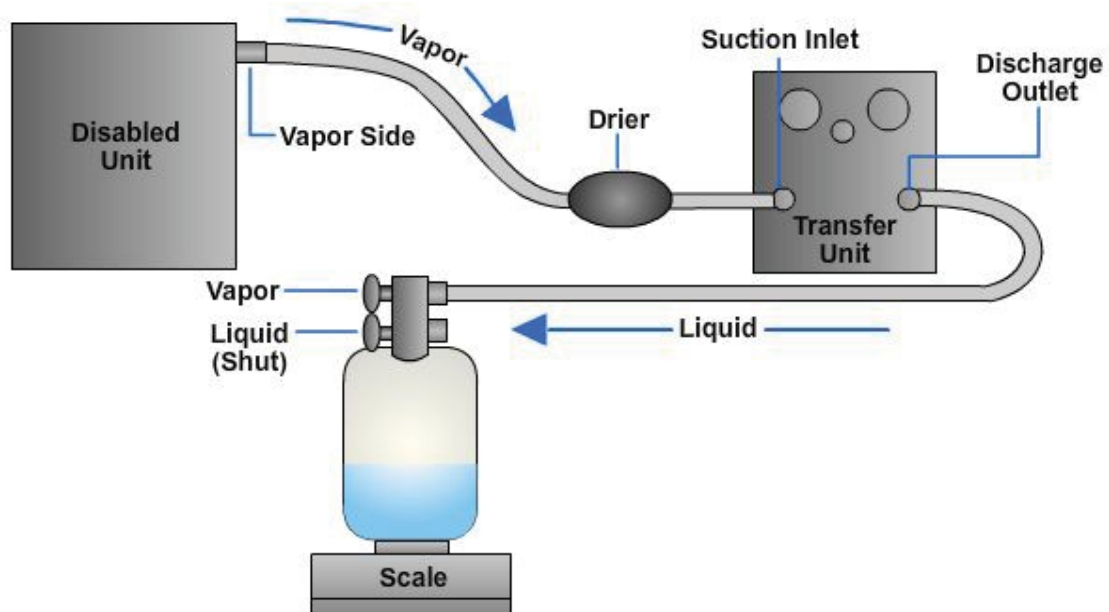

Figure 12-57 – Vapor recovery method.

In the liquid recovery method a hose is connected to the low-side access point to the transfer unit compressor discharge valve (*Figure 12-58*). Another hose is then connected from the transfer unit compressor suction valve through a filter-drier to a two-valve external storage cylinder. A third hose is connected from the high-side access point (liquid valve at the receiver) to the two-valve external storage cylinder. When the transfer unit is turned on, the transfer unit compressor pumps refrigerant vapor from the external storage cylinder into the refrigeration system, which pressurizes it. The

difference in pressure between the system and the external storage cylinder forces the liquid refrigerant from the system into the external cylinder. Once the liquid refrigerant is removed from the system, the remaining vapor refrigerant is removed using the vapor recovery method as previously described.

Most recovery units automatically shut off when the refrigerant has been completely recovered, but check the manufacturer's operational manual for specific instructions. You should make sure that the external storage cylinder is not overfilled. Eighty percent capacity is normal. If the recovery unit is equipped with a sight-glass indicator, you should note any changes that may occur.

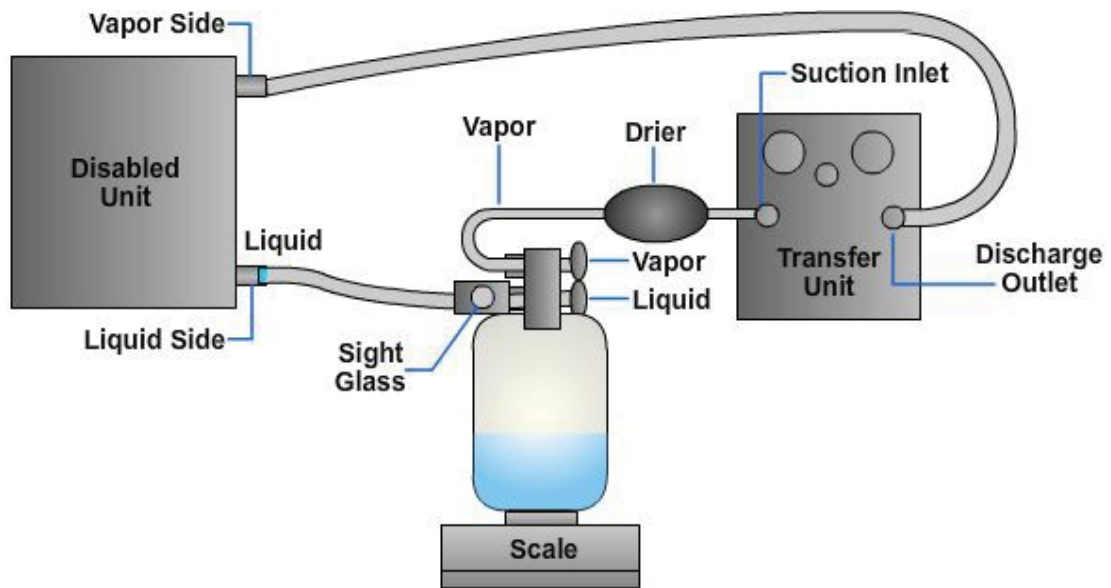

Figure 12-58 – Liquid recovery method.

7.5.2 Recycling

The process of cleaning refrigerant for reuse by oil separation and single or multiple passes through filter-driers which reduce moisture, acidity, and matter is called "recycling." In the past, refrigerant was typically vented into the atmosphere. Modern technology has developed equipment to enable reuse of old, damaged, or previously used refrigerant.

Refrigerant removed from a system cannot be simply reused—it must be clean. Recycling performed in the field by most recycling machines uses oil separation and filtration to reduce contaminants. Normally recycling is accomplished during the recovery of the vapor or liquid refrigerant by using equipment that does both recovery and recycling of refrigerant.

Recycling machines use either the single-pass or multiple-pass method of recycling. The single-pass method processes refrigerant through a filter-drier and/or uses distillation (Figure 12-59). It makes only one pass through the recycling process to a storage cylinder. The multiple-pass method re-circulates refrigerant through the filter-drier (Figure 12-60). After a period of time has elapsed or a number of cycles have occurred, the refrigerant is transferred to a storage cylinder.

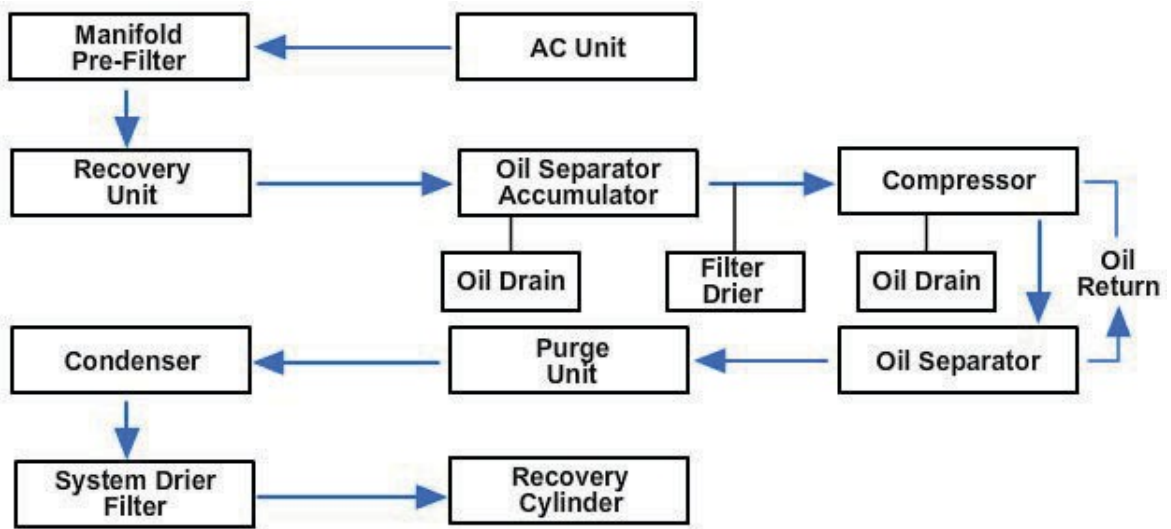

Figure 12-59 – Single-pass method of recycling.

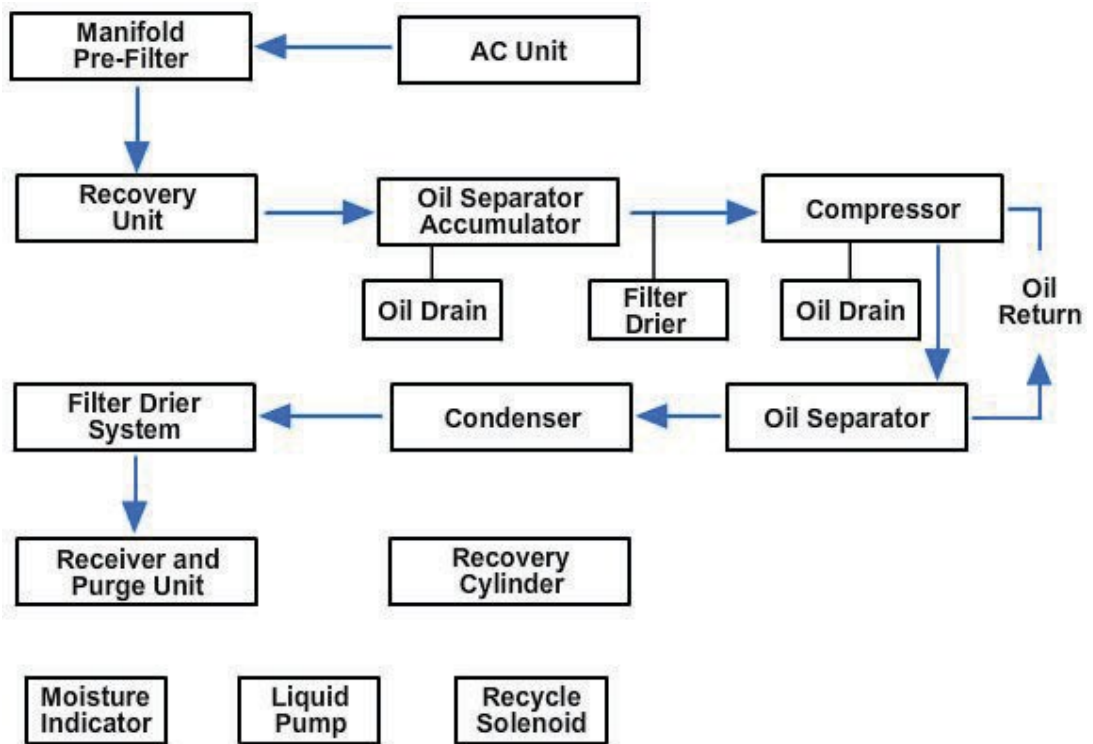

Figure 12-60 – Multiple-pass method of recycling.

7.5.3 Reclaiming

The reprocessing of a refrigerant to original production specifications after verification by chemical analysis is called "reclaiming." Equipment used for this process must meet SAE standards and remove 100 percent of the moisture and oil particles.

Most reclaiming equipment uses the same process cycle for reclaiming refrigerant. The refrigerant enters the unit as a vapor or liquid and is boiled violently at a high temperature at extreme high pressure (distillation). The refrigerant then enters a large, unique separator chamber where the velocity is radically reduced, which allows the high-temperature vapor to rise.

During this phase all the contaminants, such as copper chips, carbon, oil, and acid, drop to the bottom of the separator to be removed during the "oil out" operation. The distilled vapor then leaves the separator and enters an air-cooled condenser where it is converted to a liquid. The liquid refrigerant then passes through a filter-drier and into a storage chamber where the refrigerant is cooled to a temperature of 38°F to 40°F by an evaporator assembly.

7.6.0 Component Removal and Replacement

As a UT you are responsible for maintaining refrigerant systems at an optimum operating condition. To meet this requirement you may be assigned to remove or replace system components. Therefore, it is important that you understand the following procedures for removing and replacing system components.

7.6.1 Removing Expansion or Float Valves

To help ensure good results in removing expansion or float valves, you should pump the system down to a suction pressure of just over zero. You should do this at least three times before removing the expansion valve. Plug the opened end of the liquid line and evaporator coil to prevent air from entering the system. Repair or replace the expansion valve and connect it to the liquid valve. Crack the receiver service valve to clear air from the liquid line and the expansion valve. Connect the expansion valve to the evaporator coil inlet and tighten the connection. Pump a vacuum into the low side of the system to remove any air.

7.6.2 Replacing an Evaporator

To replace an evaporator, pump down the system and disconnect the liquid and suction lines. Then remove the expansion valve and the evaporator. Make the necessary repairs or install a new evaporator as required. Replace the expansion valve and connect the liquid and suction lines. Remove moisture and air by evacuating the system. When the evaporator is back in place, pump a deep vacuum as in starting a new installation for the first time. Check for leaks and correct them if they occur. If leaks do occur, be certain to repair them; then pump the system into a deep vacuum. Repeat the process until no more leaks are found.

7.6.3 Removing the Compressor

Using the gauge manifold and a vacuum pump, pump down the system. Most of the refrigerant will be trapped in the condenser and the receiver. To remove the compressor from service, proceed as follows:

1. Once the pump down is complete, the suction valve should already be closed and the suction gauge should read a vacuum. Mid-seat the discharge service

valve. Open both manifold valves to allow high-pressure vapor to build up the compressor crankcase pressure to 0 psi.

2. Front-seat (close) the discharge service valve. Then crack the suction service valve until the compound gauge reads 0 to 1 psi to equalize the pressures and then front-seat the valve.
3. Joints should be cleaned with a grease solvent and dried before opening. Unbolt the suction service and discharge service valves from the compressor. DO NOT remove the suction or discharge lines from the compressor service valves.
4. Immediately plug all openings through which refrigerant flows using dry rubber, "cork" stoppers, or tape.
5. Disconnect the bolts that hold the compressor to the base and remove the drive belt or disconnect the drive coupling. You can now remove the compressor.

7.6.4 Removing Hermetic Compressors

Systems using hermetic compressors are not easily repaired, as most of the maintenance performed on them consists of removal and replacement. To remove or replace a hermetic compressor, proceed as follows:

1. Disconnect the electrical circuit including the overload switch.
2. Install a gauge manifold. Use a piercing valve (Schrader) if needed
3. Remove the refrigerant using an EPA-approved recovery/recycling unit.
4. Disconnect the suction and discharge lines. Using a pinching tool, pinch the tubing on both the suction and discharge lines, and cut both lines between the compressor and the pinched area.
5. Disconnect the bolts holding the compressor to the base and remove the compressor.

If necessary, do not forget to pump down the system and equalize the suction and head pressure to the atmosphere. Wear goggles to prevent refrigerant from getting in your eyes. After replacement, the procedures given for removing air and moisture and recharging the system can be followed; however, the procedures may have to be modified because of the lack of some valves and connections. Follow the specific procedures contained in the manufacturer's manual.

Test your Knowledge (Select the Correct Response)

12. When transferring refrigerant, the amount of refrigerant that may be placed in a cylinder is what percentage of the tare-weight?
 - A. 50
 - B. 65
 - C. 70
 - D. 85

13. What is the best leak detector to use when trying to detect a halogen refrigerant leak?
- A. Hydraulic
 - B. Scanning
 - C. Halide
 - D. Electronic

8.0.0 MAINTENANCE of COMPRESSORS

In order for you to perform the required maintenance on compressors, it is important that you know the locations of the inspection points for open-type refrigeration compressors. It is also important for you to know the repair procedures for common problems associated with those types of compressors.

8.1.0 Open Types of Compressors

A vertical single-acting reciprocating compressor is shown in *Figure 12-61*. Some of the duties you may perform in maintaining this and other open-type compressors are discussed below.

8.1.1 Shaft Bellow Seal

Refrigerant leakage often occurs at the shaft bellows seal with consequent loss of charge. Install a test gauge in the line leading from the drum to the compressor. Attach a refrigerant drum to the suction end of the shutoff valve outlet port. Apply the proper amount of pressure, as recommended in the manufacturer's instructions.

Test for leaks with a halide leak detector around the compressor shaft, seal gasket, and seal nut. Slowly turn the shaft by hand. When a leak is located at the seal nut, replace the seal plate, gasket, and seal assembly; when the leak is at the gasket, replace the gasket only. Retest the seal after reassembly. (This procedure is typical for most shaft seals on reciprocating open-type compressors.)

8.1.2 Valve Obstructions

Obstructions such as dirt or corrosion may be formed under seats of suction or discharge valves. To locate the source of these problems, proceed as follows:

When the suction valve side is obstructed, the unit tends to run for long periods of time or continuously. Connect the gauge manifold and start the unit. This pressure gauge (HI) will not indicate an increase in pressure. The low-side gauge (LO) will fluctuate and will not indicate any decrease in pressure. Clean out any obstructions and recheck again by using the test gauge assembly.

If you want to determine if there is a discharge valve leak, connect the gauge manifold and start the unit. Run it until the low-side (LO) pressure gauge indicates normal pressure for the unit. Stop the unit. Place an ear near the compressor housing and listen for a hissing sound. Also, watch the gauges. When leaking caused by an obstruction is present, the low-side pressure rises, and the high side decreases until the pressures are equalized. A quick equalization of pressures indicates a bad leak that should be repaired immediately or the compressor replaced.

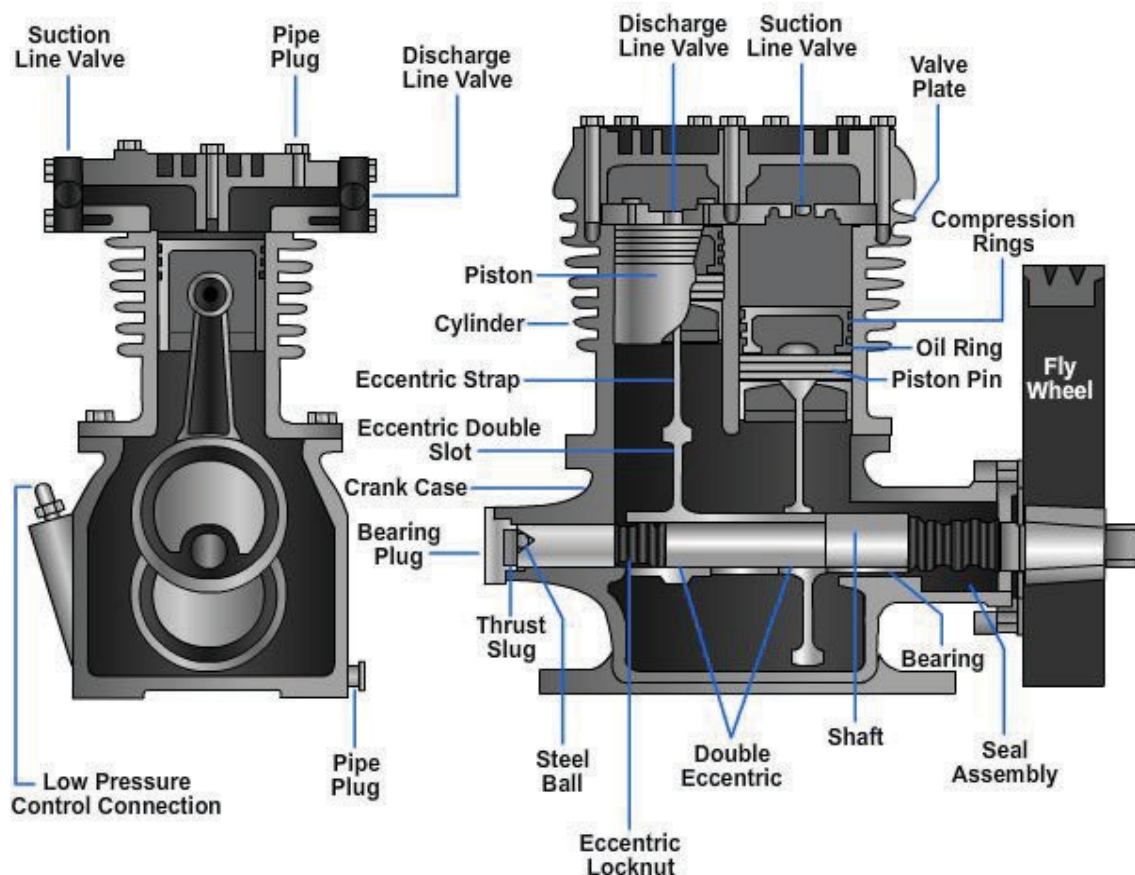

Figure 12-61 – Vertical single-acting reciprocating compressor.

8.1.3 Compressor Lubrication

The oil level in the compressor crankcase should be checked by following the procedure in the manufacturer's manual. This procedure normally includes the following steps:

1. Attach the gauge manifold to the suction and discharge service valves.
2. Pump the system down.
3. Close the suction and discharge valves, isolating the compressor.
4. Remove the oil filter plug and measure the oil level as per the manufacturer's manual.

8.1.4 Compressor Knocks

If you hear a knocking in the compressor, you may have to disassemble the compressor to determine whether the cause is a loose connecting rod, piston pin, or crankshaft. Sometimes a loose piston can be detected without doing a complete disassembly of the compressor. In cases requiring disassembly, you should take the following steps:

1. Remove the cylinder head and valve plate to expose the top of the piston.
2. Start the motor and press down on the top of the piston with your finger. If you feel any looseness with each stroke of the piston, replace the loose part.
3. Check the oil level because oil levels that are too high can cause knocks. Always make sure that a low oil level is actually the result of a lack of oil, rather than a low charge.

8.1.5 Stuck or Tight Compressor

A stuck or tight compressor often occurs as a result of poor reassembly after a breakdown repair. In such cases, determine where the binding occurs and reassemble the unit with correct tolerances; avoid uneven tightening of screws or seal covers.

8.2.0 Inspection of Compressors

From time to time you will have to perform an inspection on a refrigeration unit. During the inspection you should have the unit operating, then check for knocks, thumps, rattles, and other noises. Make sure you clean any of the external parts that have excessive grease, dirt, or lint on them. Before beginning any cleaning, you should always ensure the power is off.

It is essential that you do a careful check of the entire system using the required instruments and tools to determine if there is any loss of refrigerant.

Remember, **NO LEAK IS TOO SMALL TO BE FIXED**. Each leak must be stopped immediately.

Some specific conditions to look for during the inspection of a refrigeration system are as follows:

- Check for inadequate lubrication of bearings and other moving parts.
- Rusty or corroded parts discovered during the inspection should be cleaned and painted.
- Hissing sounds at the expansion valve, low readings on the discharge pressure gauge, and bubbles in the receiver sight glass all indicate a weak refrigerant charge.
- Loose connections and worn or pitted switch contacts result in inoperative equipment or reduced reliability.
- Thermostats with burned contacts may produce abnormal temperatures in the cooled compartment.
- Fans with bent blades, loose or worn belts are hard to rotate by hand and can cause problems. During inspections, fan troubles are easy to locate and correct.

- Air filters clogged with dirt should be cleaned or replaced during the inspection.
- Hermetically sealed units should be inspected for signs of leaks and high temperatures and for too much noise or vibration.

Test your Knowledge (Select the Correct Response)

14. What unit valve is considered to be obstructed when the unit runs continuously?
- Detector
 - Suction
 - Shutoff
 - Discharge
15. What can cause the unit's compressor to become stuck or tight?
- Loose piston pin
 - Excessive grease
 - Poor reassembly
 - Clogged air filter

9.0.0 MAINTENANCE of MOTORS

As a UT, you need to have an understanding of the basic maintenance and the troubleshooting methods used for electrical motors.

Mechanical and electrical are the types of problems you may encounter with electrical motors used to drive the compressors of mechanical refrigeration systems.

9.1.0 Mechanical Problems

The electrical motors of some compressors are belt-driven, which means you will have to adjust the belt tension and pulley alignment for proper operation. The belt tension should be adjusted so 1-pound of force on the center of the belt, either up or down, does not depress it more than one-half inch. To adjust the alignment, loosen the setscrew on the motor pulley after tension adjustment is made. Be sure the pulley turns freely on the shaft; add a little oil if necessary. Turn the flywheel forward and backward several times. When it is correctly aligned, the pulley does not move inward or outward on the motor shaft. Tighten the setscrew holding the pulley to the shaft before starting the motor.

Compressors may also be driven directly by a mechanical coupling between the motor and compressor shafts. Be sure the two shafts are positioned so they form a straight line with each other. The coupling on direct drive units should be realigned after repair or replacement. Clamp a dial indicator to the motor half coupling with its pointer against the outer edge of the compressor half coupling. Rotate the motor shaft, and observe any fluctuations of the indicator. Move the motor or compressor until the indicator is stationary when revolving the shaft one full turn. Secure the hold-down bolts and then recheck.

9.1.1 Moisture in the System

When liquid refrigerant that contains moisture vaporizes, the moisture separates from the vapor. Because the vaporization of the refrigerant causes a cooling effect, the water that has separated can freeze. Most of the expansion and vaporization of the refrigerant

occurs in the evaporator. However, a small amount of the liquid refrigerant vaporizes in the expansion valve, and the valve is cooled below the freezing point of water. As a result, ice can form in the expansion valve and interfere with its operation. If the needle in the valve freezes in a slightly off-seat position, the valve cannot permit the passage of enough refrigerant. If the needle freezes in a position far from the seat, the valve feeds too much refrigerant. In either case, you must observe all precautions to assure the system stays moisture-free.

A dehydrator is filled with a chemical known as a desiccant, which absorbs moisture from the refrigerant passing through the dehydrator (*Figure 12-62*). Dehydrators are installed in the liquid line to absorb moisture in the system after the original installation. An arrow on the dehydrator indicates the direction of flow. Desiccants are granular and are composed of silica gel, activated alumina, or calcium sulfate. Do not use calcium chloride or chemicals that form a nonfreezing solution. These solutions may react with moisture to form undesirable substances, such as gums, sledges, or waxes. Follow the manufacturer's instructions as to limitations of dehydrators, as well as operation, recharging, replacing, and servicing.

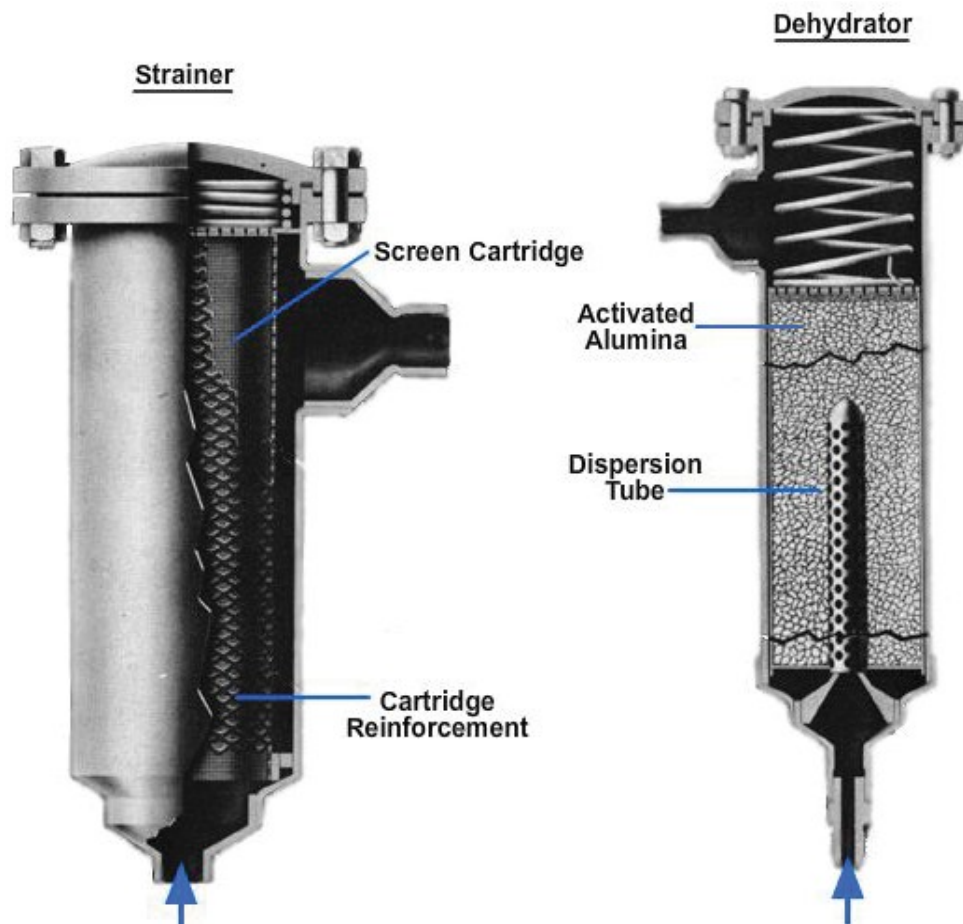

Figure 12-62 —Refrigeration dehydrator

9.1.2 Loose Copper Tubing

In sealed units, loose copper tubing is usually detected by the sound of rattling or metallic vibration. Bending the tubing carefully to the position of least vibration usually eliminates the defect. Do not touch it against other tubing or parts at a point of free movement, and do not change the tubing pitch or the tubing diameter by careless bending.

In open units, lengths of tubing must be well supported by conduit straps or other devices attached to walls, ceilings, or fixtures. Use friction tape pads to protect the copper tubing from the metal of the strap. When two tubes are together in a parallel position, wrapping and binding them together with tape can prevent vibration. When two lines are placed in contact for heat exchange, they should be soldered to prevent rattling and to permit better heat transfer.

9.1.3 Doors and Hardware

If you have to replace door hinges because they lack lubrication or have other problems, replace them with same type of hinges, when possible. If you find any loose hinge pins you should securely braid them. When thrust bearing are provided, they are held in place by a pin.

The latch or catch is usually adjusted for proper gasket compression. Shims or spacers may be added or removed for adjustment. Latch mechanisms should be lubricated and adjusted for easy operation. Latch rollers must not bind when operated. Be sure to provide sufficient clearance between the body of the latch and catch, so no contact is made. The only contact is made between the catch and the latch bolt or roller. These instructions also apply to safety door latches when they are provided for opening the door from the inside, although it is locked from the outside.

A lack of complete gasket contact between the door overlap and the doorframe is usually caused by a warped door. This condition can be corrected if you install a long tapered wooden shim or splicer under the door seal. If this does not tighten the door to the frame, remove the door and realign or rebuild it.

If you find any door gaskets that are missing, worn, warped, or loose, you should repair or replace them. When the gasket is clamped or held in place by the doorframe or the door panel, use the same type of gasket to replace it. In either case, the gasket should be installed so when the door is closed a complete and uniformly tight seal results.

When condensation causes the doors to freeze shut, you should apply a light coat of glycerin on the gaskets.

9.1.4 Defrosting

Setting the low-pressure control switch to a predetermined level will usually defrost cooling units in the 35°F to 45°F refrigerators or cold storage rooms. Manual defrosting is required if this setting causes an overload, resulting in heavy frosting of the coil.

Cooling units with temperatures of 35°F and lower are defrosted manually. The most common method for manual defrosting is to spray water over the cooling coil. Warm air, electric heating, or hot gas refrigerant can also be used for defrosting. In any case, the fans must not be in operation during the defrosting.

Plate-type evaporator banks in below-freezing refrigerators should be defrosted when the ice becomes one-half inch thick. They should also be defrosted when the buildup of ice affects the temperature of the fixtures or the suction pressure. Before removing frost from the plates, place a tarpaulin on the floor or over the contents of the refrigerator to catch the frost under the bank.

9.2.0 Electrical Defects

The control systems for modern refrigeration systems are composed of many components that use or pass electrical power. These components include compressor drive motors, pressure switches, thermostats, and solenoid stop valves. Although you are not responsible for troubleshooting these electrical components, you must be able

to use the multi-meter for locating opens, shorts, and grounds, and measuring voltage and current. Navy Electricity and Electronics Training Series (NEETS), NAVEDTRA 14175, *Introduction to Circuit Protection, Control, and Measurement* will help you in learning to use electrical meters and testing equipment.

9.2.1 Opens

Figure 12-63, View A, shows a simple refrigeration control system. You have learned the basics of electricity and how to use meters. Using this figure, you will put that knowledge to work. Remember, if you are having problems, call your supervisor or arrange for a Construction Electrician to help you.

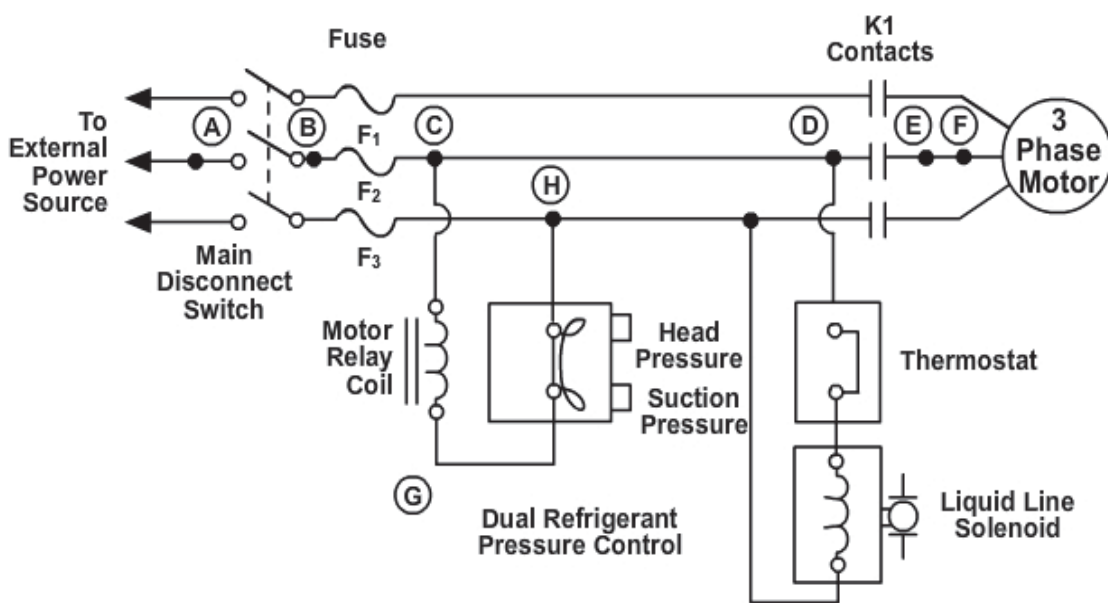

Figure 12-63 – Simple refrigeration control system.

An "open" is defined as the condition of a component that prevents it from passing current. It may be a broken wire, a burned or pitted relay contact, a blown fuse, a broken relay coil, or a burned-out coil winding. An open can be located in one of two ways.

A voltmeter should be used for the components in series, such as the main disconnect switch, fuses, the wire from Point C to Point D (*Figure 12-63*), the relay contacts, and the wire from Point E to Point F. Set up the voltmeter to measure the source voltage (120 volts ac, in this case). If the suspected component is open, the source will be measured across it. To check part of the main disconnect switch, close the switch and measure from Point A to Point B. If the meter reading is 0 volts, that part of the switch is good; if the voltage equals the source voltage, the switch is open.

To check the fuse F2, measure across it, Point B to Point C as shown in *Figure 12-63, view B*. Measuring across Points C and D or E and F will check the connecting wires for opens. One set of relay contacts can be checked by taking meter readings at Points D and E. These are just a few examples, but the rule of series components can always be applied. Remember, the three sets of contacts of relay K1 will not close unless voltage is present across the relay coil; the coil cannot be open or shorted. When testing an electrical circuit, follow the safe practices you have been taught and use procedures outlined in equipment manuals.

Opens in components that are in parallel cannot easily be found with a voltmeter because, as you know, parallel components have voltage across them at all times when the circuit is energized. In *Figure 12-63*, the branch with the motor relay K1 and the dual refrigerant pressure control are considered a parallel circuit because when the main disconnect switch is closed and the fuses are good, there is voltage between Points C and H, regardless of whether the relay coil and pressure switch are open.

To check for opens in these components, use an ohmmeter set at a low range. Disconnect all power by opening (and locking out, if possible) the main disconnect switch. This action removes all power and ensures both personal and equipment safety. To check the motor relay K1 to see if its coil is open, put the ohmmeter leads on Points C and G. A reading near infinity (extremely high resistance) indicates an open. The contacts of the dual refrigerant pressure control can be tested by putting the ohmmeter leads from Point G to Point H. Again, a reading near infinity indicates open contacts.

You may need to consult the manufacturer's manual for the physical location of Points G and H. Notice the contacts of the control are normally closed when neither the head pressure nor the suction pressure is above its set limits.

9.2.2 Shorts

Shorts are just the opposite of opens. Instead of preventing the flow of current, they allow too much current to flow, often blowing fuses. The ohmmeter on its lowest range is used to locate shorts by measuring the resistance across suspected components. If the coil of the motor relay K1 is suspected of being shorted, put the leads on Points C and G as shown in *Figure 12-63, View C*. A lower than normal reading (usually almost zero) indicates a short. You may have to determine the normal reading by consulting the manufacturer's manual or by measuring the resistance of the coil of a known good relay. If fuses F2 and F3 blow and you suspect a short between the middle and bottom lines (*Figure 12-63*), put the ohmmeter leads between Points C and H. Again, a low reading indicates a short. Remember, in all operations using an ohmmeter, it is imperative that all power be removed from the circuit for equipment and personal safety. Do not fail to do this!

9.2.3 Grounds

A ground is an accidental connection between a part of an electrical circuit and ground, due perhaps, to physical contact through wearing of insulation or movement. To locate a ground, follow the same procedure you used to locate a short. The earth itself, a cold-water pipe, or the frame of a machine, are all examples of ground points.

To see whether a component is shorted to ground, put one ohmmeter lead on the ground and the other on the point suspected to be grounded and follow the rules for locating a short.

Be sure to turn off all power to the unit. It may even be wise to check for the presence of voltage first. Use a voltmeter set to the range suitable for measuring source voltage. If power does not exist, then use the ohmmeter.

The limited amount of instruction presented here is not enough to qualify you as an electrician, but it should enable you to find such troubles as blown fuses, poor electrical connections, and the like. If the trouble appears more complicated than this, call your supervisor or ask for assistance from a Construction Electrician.

9.2.4 Testing the Motor

As a UT, you should be able to make voltage measurements in a refrigeration system to ensure the proper voltage is applied to the drive motor, as shown on the motor's rating plate. If the proper voltage is applied (within 10 percent) to the terminals of the motor and it does not run, you must decide what to do. If it is an open system (not hermetically sealed), it is the Construction Electrician's job to repair the motor. If it is a hermetically sealed unit, you must try to make the motor operational again by completing further tests using special test equipment.

If the unit doesn't run, it may be because the motor rotor or compressor crankshaft is stuck (remember, in a hermetically sealed unit, they are one and the same). If you apply electrical power to try and move the motor in the correct direction first and then reverse the power, you may be able to rock it free and not have to replace the unit. This is one of the purposes of the hermetic unit analyzer (*Figure 12-64*). Use the following steps to rock the rotor of a hermetically sealed unit:

1. Determine from the manufacturer's manual whether the motor is a split-phase or a capacitor-start type.
2. Remove any external wiring from the motor terminals.
3. Place the analyzer plugs in the jacks of the same color. If a split-phase motor is used, put the red plug in jack No. 3; if the capacitor-start motor is used, put the red plug in jack No. 4; and select a capacity value close to the old one with the toggle switches.
4. Connect the test clips as follows:
 - White to common
 - Black to the running winding
 - Red to the starting winding

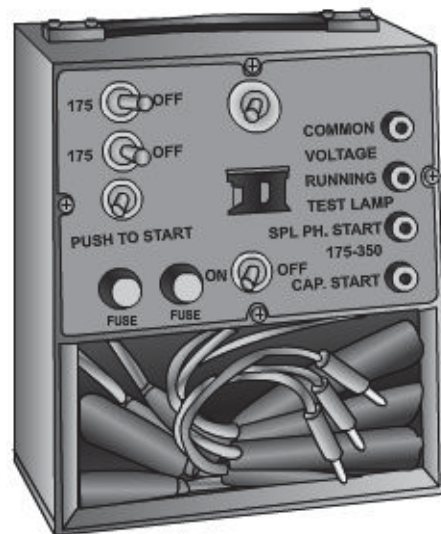

Figure 12-64 – Hermetic unit analyzer.

5. Hold the push-to-start button down and at the same time move the handle of the rocker switch from normal to reverse. The frequency of rocking should not exceed five times within a 15-second period. If the motor starts, be certain that the rocker switch is in the normal position before releasing the push-to-start button.
6. More tests can be made with the hermetic unit analyzer, such as testing for continuity of windings and for grounded windings. Procedures for these tests are provided in the manual that comes with the analyzer. Generally, if the rocking procedure does not result in a free and running motor, the unit must be replaced.

9.3.0 Troubleshooting Refrigeration Equipment

Troubleshooting of any type of refrigeration unit depends on your ability to compare normal operation with that obtained from the unit being operated. Obviously for you to detect these abnormal operations, you must first know what normal operation is.

Climate affects running time. A refrigeration unit generally operates more efficiently in a dry climate. In an ambient temperature of 75°F, the running period usually approximates 2 to 4 minutes, and the off period, 12 to 20 minutes.

It is beyond the scope of this text to cover all of the troubles you may encounter in working with refrigeration equipment. If you apply yourself, you can acquire a lot of additional information through on-the-job training and experience and studying the manufacturer's instruction manuals.

First and foremost, safety must be stressed and safe operating practices followed before and while doing any troubleshooting or service work. All local and national codes must be observed, as well as DoD rules concerning safety. Some of the more important safety steps that are often overlooked are as follows:

- Protective equipment, such as eye protection, gloves, hard hats, and so forth must be available and worn.
- Fire extinguishers must be readily available, in good working order, and adequate for the situation.
- Safety tags with such notations as "Danger," "Hands Off," "Do Not Operate," and "Do Not Throw Switch" should be attached to valves and switches, and at other strategic locations when servicing or making repairs.
- Install machinery guards properly before operating machinery.

The above is only a short list and not intended to be all-inclusive. You will also find *Table 12-3* (discussed earlier in this chapter), and *Table 12-5* (shown below) useful guides for locating and correcting different troubles in refrigeration equipment.

Table 12-5 – Troubleshooting Industrial Refrigeration

PROBLEM	POSSIBLE CAUSE	REMEDY OR COMMENT
Compressor will not start	No power to motor.	Check power to and from fuses; replace fuses if necessary. Check starter contacts, connections, overloads, and timer (if part winding start). Reset or repair as necessary. Check power at motor terminals. Repair wiring, if damaged.

Table 12-5 – Troubleshooting Industrial Refrigeration (cont.)

PROBLEM	POSSIBLE CAUSE	REMEDY OR COMMENT
Compressor will not start (cont.)	Control circuit is open.	<p>Safety switches are holding circuit open.</p> <p>Check high pressure, oil failure, and low-pressure switches. Also check oil filter pressure differential switch is supplied.</p> <p>Thermostat is satisfied</p> <p>Check control circuit fuses if blown; replace.</p> <p>Check wiring for open circuit.</p>
Motor "hums" but does not start	Low voltage to motor.	<p>Check incoming power for correct voltage. Call power company or inspect/repair power wiring.</p> <p>Check at motor terminals. Repair or replace as necessary.</p>
	Motor shorted.	Check at motor terminals. Repair or replace as necessary.
	Single-phase failure in the three-phase power supply.	Check power wiring circuit for component or fuse failure.
	Compressor is seized due to damage or liquid.	Remove belts or coupling. Manually turn crankshaft to check compressor.
	Compressor is not unloaded.	Check unloader system.
Compressor starts but motor cycles off on overloads	Compressor has liquid or oil in cylinders.	<p>Check compressor crankcase temperature.</p> <p>Throttle suction stop valve on compressor to clear cylinders and act to prevent recurrence of liquid accumulation.</p>
	Suction pressure is too high.	<p>Unload compressor when starting. Use internal unloaders if present.</p> <p>Install external bypass unloader.</p>
	Motor control.	<p>Motor control located in hot ambient.</p> <p>Low voltage.</p> <p>Motor overloads may be defective or weak.</p> <p>Check motor control relay.</p> <p>Adjust circuit breaker setting to full load amps.</p>
	Bearings are "tight."	<p>Check motor and compressor bearings for temperature.</p> <p>Lubricate motor bearings.</p>
	Motor is running on single-phase power.	Check power lines, fuses, starter, motor, etc., to determine where open circuit has occurred.

Table 12-5 – Troubleshooting Industrial Refrigeration (cont.)

PROBLEM	POSSIBLE CAUSE	REMEDY OR COMMENT
Compressor starts but short cycles automatically	Low refrigerant charge.	Check refrigerant level and add if necessary
	Driers plugged or saturated with moisture.	Replace cores.
	Refrigerant feed control is defective.	Repair or replace.
	No load.	To prevent short cycling, if objectionable, install pump-down circuit, anti-recycle timer or false load system.
	Unit is too large for load.	Reduce compressor speed. Install false load system.
	Suction strainer blocked or restricted.	Check and clean or replace as necessary.
Motor is noisy or erratic	Motor bearing failure or winding failure.	Check and repair as needed.
	If electric starter, check calibration on control elements.	Adjust as necessary.
Compressor runs continuously but does not keep up with the load	Load is too high.	Speed up compressor or add compressor capacity. Reduce load.
	Refrigerant metering device is underfeeding causing compressor to run at too low a suction pressure.	Check and repair liquid feed problems. Check discharge pressure and increase if low.
	Faulty control circuit, may be low pressure control or capacity controls.	Check and repair.
	Compressor may have broken valve plates.	Check compressor for condition of parts. This condition can usually be detected by checking compressor discharge temperature.
	Thermostat control is defective and keeps unit running.	Check temperatures of product or space and compare with thermostat control. Replace or readjust thermostat.
	Defrost system on evaporator not working properly.	Check and repair as needed.
	Suction bags in strainers are dirty and restrict gas flow.	Clean or remove.
	Hot gas bypass or false load valve stuck.	Check and repair or replace.

Table 12-5 – Troubleshooting Industrial Refrigeration (cont.)

PROBLEM	POSSIBLE CAUSE	REMEDY OR COMMENT
Compressor loses excessive amount of oil	High suction superheat causes oil to vaporize.	Insulate suction lines Adjust expansion valves to proper superheat. Install liquid injection (suction line desuperheating).
	Too low of an operating level in chiller will keep oil in vessel.	Raise liquid level in flooded evaporator (R-12 systems only)
	Oil not returning from compressor.	Make sure all valves are open. Check float mechanism and clean orifice. Check and clean return line.
	Oil separator is too small.	Check selection.
	Broken valves cause excessive heat in compressor and vaporization of oil.	Repair compressor.
	"Slugging" of compressor with liquid refrigerant that causes excessive foam in the crankcase.	"Dry up" suction gas to compressor by repairing evaporator. Refrigerant feed controls are overfeeding. Check suction trap level controls. Install a refrigerant liquid transfer system to return liquid to high side.
Noisy compressor operation	Loose flywheel or coupling.	Tighten.
	Coupling not properly aligned.	Check and align if required.
	Loose belts.	Align and tighten per specs. Check sheave grooves.
	Poor foundation or mounting.	Tighten mounting belts, grout base, or install heavier foundation.
	Check compressor with stethoscope if noise is internal.	Open, inspect, and repair as necessary.
	Check for liquid or oil slugging.	Eliminate liquid from suction mains. Check crankcase oil level.
Low evaporator capacity	Inadequate refrigerant feed to evaporators.	Clean strainers and driers. Check expansion valve superheat setting. Check for excessive pressure drop due to change in elevation, too small of lines (suction and liquid lines). A heat exchanger may correct this. Check expansion valve size.

Table 12-5 – Troubleshooting Industrial Refrigeration (cont.)

PROBLEM	POSSIBLE CAUSE	REMEDY OR COMMENT
Low evaporator capacity (cont.)	Expansion valve bulb in a trap.	Change piping or bulb location to correct.
	Oil in evaporator.	Warm the evaporator, drain oil, and install an oil trap to collect oil.
	Evaporator surface fouled.	Clean.
	Air or product velocity is too low.	Increase to rated velocity. Coil not properly defrosting. Check the defrost time. Check method of defrost.
	Brine flow through evaporator may be restricted.	Chiller may be fouled or plugged. Check re-circulating pumps. Check process piping for restriction.
Discharge pressure too high	Air in condenser.	Purge non-condensibles.
	Condenser tubes fouled.	Clean.
	Water flow inadequate.	Check water supply and pump. Clean control valve. Check water temperature.
	Airflow is restricted.	Check and clean: Coils, Eliminators, and Dampers.
	Liquid refrigerant backed up in condenser.	Find source of restriction and clear. If system is overcharged, remove refrigerant as required. Check to make sure equalizer (vent) line is properly installed and sized.
	Spray nozzles on condensers plugged.	Clean
Discharge pressure too low	Ambient air is too cold.	Install a fan cycling control system.
	Water quantity not being regulated properly through condenser.	Install or repair water regulating valve.
	Refrigerant level low.	Check for liquid seal, add refrigerant if necessary.
	Evaporative condenser fan and water switches are improperly set.	Reset condenser controls.
Suction pressure too low	Light load condition.	Shut off some compressors. Unload compressors. Slow down RPM of compressor. Check process flow.

Table 12-5 – Troubleshooting Industrial Refrigeration (cont.)

PROBLEM	POSSIBLE CAUSE	REMEDY OR COMMENT
Suction pressure too low (cont.)	Short of refrigeration.	Add refrigerant if necessary.
	Evaporators not getting enough refrigerant.	Discharge pressure too low. Increase to maintain adequate refrigerant flow. Check liquid feed lines for adequate refrigerant supply. Check liquid line driers.
	Refrigerant metering controls are too small.	Check superheat or liquid level and correct as indicated.
Suction pressure too high	Low compressor capacity.	Check compressors for possible internal damage. Check system load. Add more compressor capacity.

Test your Knowledge (Select the Correct Response)

16. **(True or False).** The coupling on the shaft of direct drive motors should be realigned after any repair or replacement.
 - A. True
 - B. False

17. Manually defrosting is normally required on refrigeration units that operate at what temperature?
 - A. 50°F
 - B. 45°F
 - C. 40°F
 - D. 35°F

10.0.0 LOGS

As a UT, you need to have an understanding of the importance and use of maintaining, operating, and inspecting logs for refrigeration equipment.

When you are maintaining, standing watch, operating, or inspecting refrigerating equipment, you may be responsible for keeping equipment operation, inspection, or maintenance logs. Try to keep the logs neat and clean. You must ensure that any information recorded in them is accurate and legible.

Operation and maintenance logs can help you spot trouble in the equipment. They also aid in ensuring proper periodic maintenance and inspection are performed on the equipment. Logs may provide a means of self-protection when trouble occurs and the cause can be placed on an individual.

Good judgment must always be used in analysis of service troubles; and whenever possible, specific corrections should be followed. When equipment is not operating properly, one method for determining when and what corrective measures are necessary is to compare current and past readings. Specifically, compare the pressures and temperatures of various parts of the system with corresponding readings taken in

the past when the equipment was operating properly. Keep in mind that the readings must be taken under similar heat load and circulating water temperature conditions.

A typical operating log may contain the following types of entries:

- Date and time of readings
- Ambient temperature
- Suction pressure and temperature readings
- Discharge pressure and temperature readings
- Condenser pressure and temperature
- Evaporator pressure and temperature
- Oil level in the compressor
- Operating hours

These types of readings give you a complete picture of the current and past operating conditions of the equipment. They can also assist you in keeping the equipment at its maximum efficiency.

Maintenance logs contain entries of when, what, and who performed routine periodic maintenance on the equipment. Such logs help ensure that the equipment is well maintained, and there is full use of the equipment's life expectancy. These logs also assist in determining estimates for future budget requirements for maintaining the equipment. Maintenance log entries may include the following:

- Date of maintenance
- Type of maintenance
- What was done
- Who did the work
- Cost of the work
- Materials used

It is important to compare equipment operating log readings before and after the maintenance was completed. This comparison helps ensure that the maintenance was accomplished properly, with no ill effects on the equipment.

Summary

Refrigeration systems are of the utmost importance for preserving medicine, blood, and most important, keeping food from spoiling. In this chapter you were introduced to the stages of heat theory and the principles involved in heat transfer. It also described how to recognize refrigeration system components along with their application. Finally, this chapter described how to recognize the characteristics and procedures required to service and troubleshoot refrigeration system equipment.

Trade Terms Introduced in this Chapter

British Thermal Unit (BTU)	The amount of heat required to raise the temperature of 1 lb. of water 1°F.
Chlorofluorocarbon (CFC)	An organic compound that contains carbon, chlorine, and fluorine, produced as a volatile derivative of methane and ethane.
Hydrochlorofluorocarbon (HCFC)	A group of man-made compounds containing hydrogen, chlorine, fluorine and carbon, used for refrigeration, aerosol propellants, foam manufacture and air conditioning.
Azeotropic	A mixture of two or more liquids (chemicals) in such a ratio that its composition cannot be changed by simple distillation.
Hydrofluorocarbon (HFC)	A synthetic refrigerant developed for refrigeration systems that need a low-evaporating temperature. It is also a fluorocarbon emitted as a by-product of industrial manufacturing.
Haloalkane	An organic chemical compound consisting of an alkane in which one or more hydrogen atoms have been substituted by a halogen element. Used as solvents and in organic synthesis.
Tare Weight	Also called un-laden weight is the weight of an empty vehicle or container. By subtracting it from the gross weight (laden weight), the weight of the goods carried (the net weight) may be determined.
Incandescence it visible.	An emission by a hot body of radiation that makes

Additional Resources and References

This chapter is intended to present thorough resources for task training. The following reference works are suggested for further study. This is optional material for continued education rather than for task training.

Introduction to Circuit Protection, Control, and Measurement, NAVEDTRA 14175, Naval Education and Training Professional Development and Technology Center, Pensacola, FL, 1998.